

EN54 CEILING SPEAKER

- 6W 100V LOUDSPEAKER
- SIZE 6.5" (165MM)
- QUICK MOUNT
- SHOCK-RESISTANT HOUSING
- HIGH EFFICIENCY
- EXCELLENT SOUND QUALITY
- FULLY CERTIFIED TO EN54-24



OVERVIEW

The SPCF-06W-65-EN54 is a 6W 100V flush mount ceiling loudspeaker, which has a 6.5" (165mm) full-range chassis providing excellent sound quality with speech and background music, and which is certified to EN54-24. The speaker is fitted with a 100V transformer which has three power adjustment tapings of 6W, 3W, and 1.5W.

The SPCF-06W-65-EN54 has a powder coated metal chassis and grille, with the high quality finish giving good long-term protection and resistance to corrosion. The speaker is supplied with a rear fire dome, and its enclosure is ingress protection rated to IP21C. As standard the speaker is coloured to match RAL9010 'Pure White', however the speakers can be supplied in any four-digit RAL or NCS colour, as a special order.

Quick and easy ceiling mounting is provided through the use of spring clamps, with a possible ceiling thickness of between 2mm and 45mm, and an inner ring attachment prevents the grille from falling. The 100V loudspeaker line cabling is connected by means of a two-pin ceramic block, with rubber grommets being provided for the cable connections. For additional reliability, a thermal fuse is provided and the speaker chassis is damp-resistant.

Please note that although very thin ceilings can be used as a mounting surface, it should be ensured that the ceiling thickness and strength are appropriate to the weight of the speaker, and to the thickness and weight of the 100V line cable.

The loudspeaker is optionally available with a DC blocking capacitor fitted, in order to provide compatibility with DC loudspeaker line monitoring systems. The part number for this DC monitoring compatible version is SPCF-06W-65-EN54-DC.

EASE data is available for this speaker on request.

PRODUCT ATTRIBUTES

Power Tappings	6W / 3W / 1.5W
Frequency Range	404 – 10,100 Hz
Frequency Response	80 – 24,000 Hz
SPL 1W / 1m, peak	102.5 dB
SPL 1W / 4m, peak	90.5 dB
SPL Pmax / 4m, peak	98.2 dB
Sensitivity EN54-24, 1W / 4m	78.0 dB
Dispersion (-6dB, 500Hz)	180°
Dispersion (-6dB, 1KHz)	180°
Dispersion (-6dB, 2KHz)	128°
Dispersion (-6dB, 4KHz)	55°
Temperature Range	-20 / +80 °C
Dimensions	220 x 112 mm
Weight (net)	1.30 kg
Colour	RAL 9010 'Pure White'
Connector	2-pin ceramic block
Mounting	Quick fit mounting
Ceiling Cut-out	198 mm
IP Rating	IP21
Maximum cable cross section	8mm ²
Maximum cable cross section loop	2 x 2mm ²
Packing Unit	12

POLAR DIAGRAM

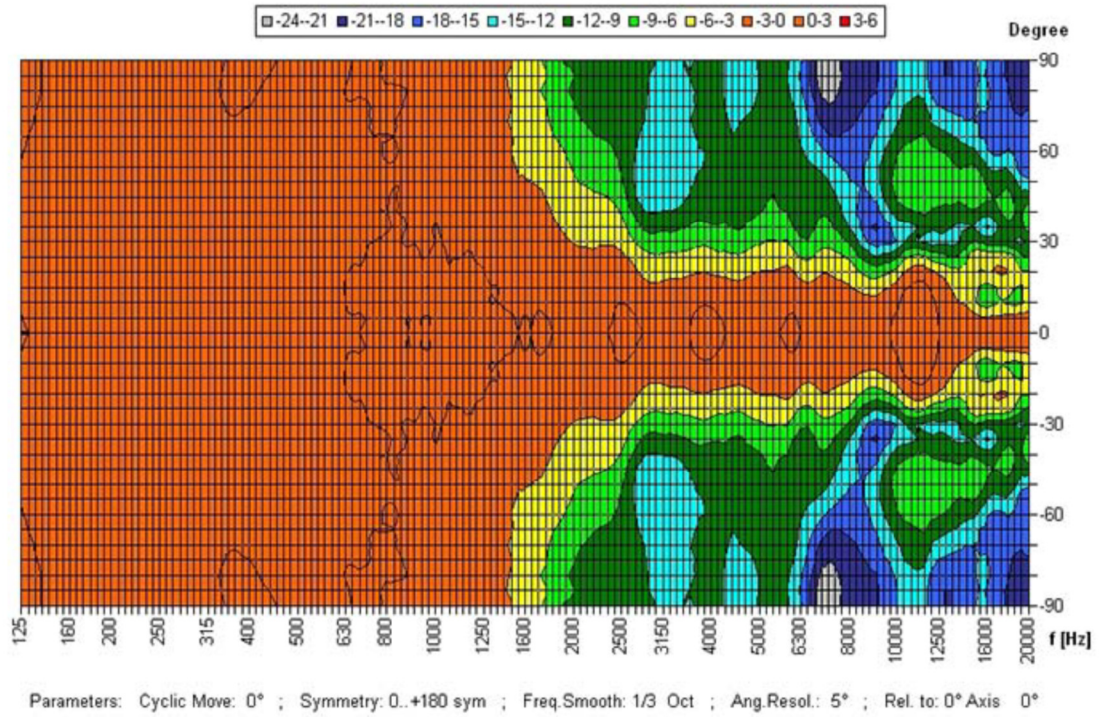

FREQUENCY RESPONSE DIAGRAM

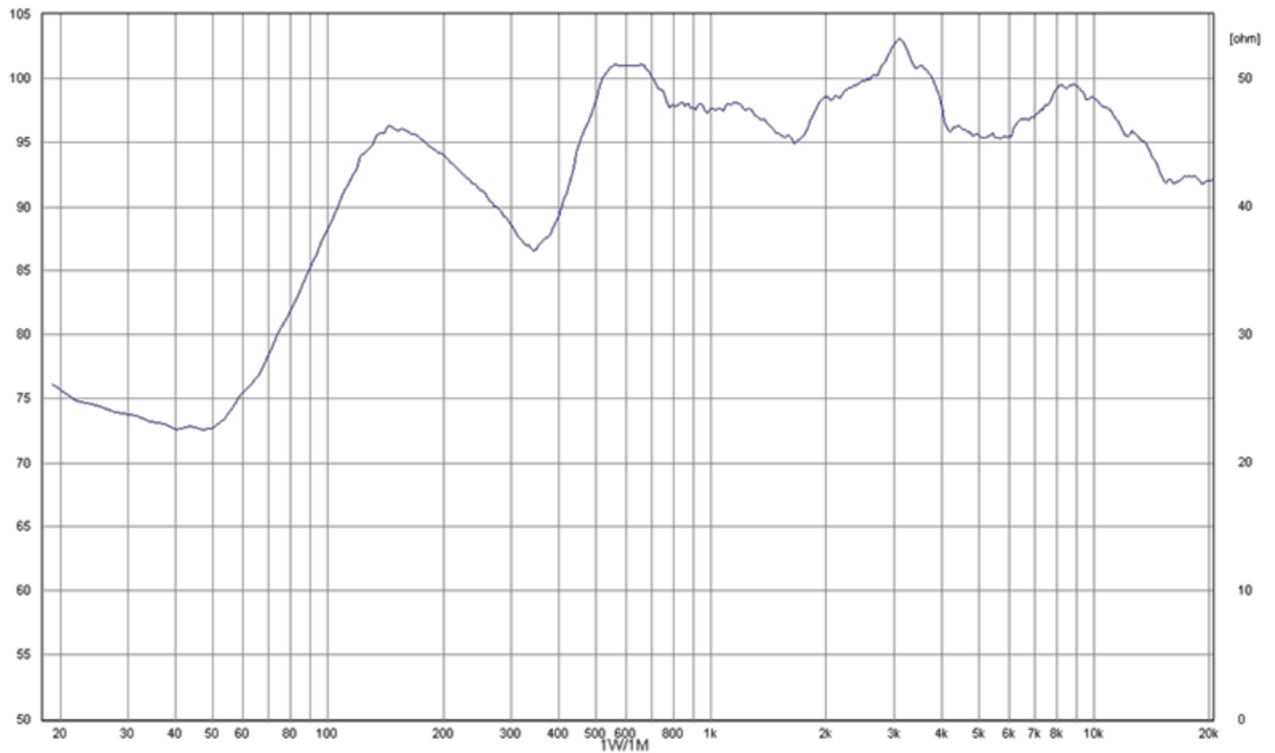

DIMENSIONAL DIAGRAM

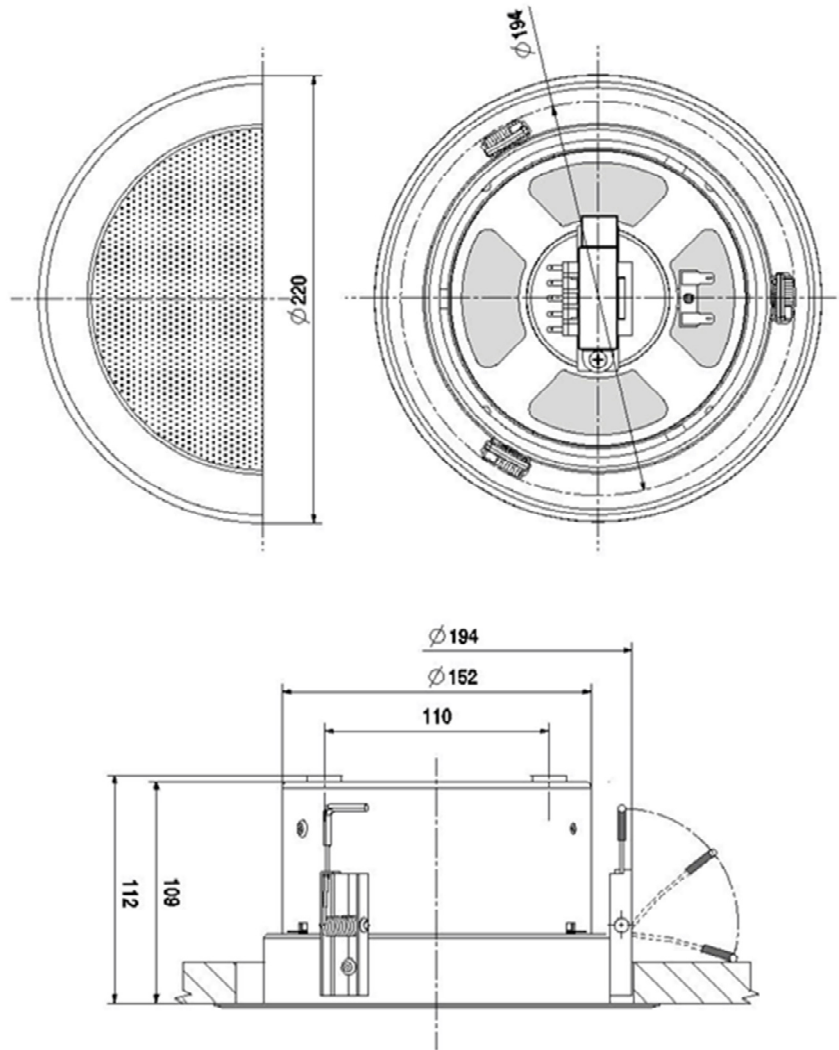

Measurements according to DIN IEC 268-5

RoHS complaint (2011/65/EU)

Made for:

Application Solutions (Safety and Security) Limited
 Unit 17 - Cliffe Industrial Estate - Lewes - East Sussex - BN8 6JL - U.K.
 Tel: +44(0)1273 405411

www.asl-control.co.uk



**Assessed to ISO 9001
 LPCB Cert No: C1043**

All rights reserved.

Information contained in this document is believed to be accurate, however no representation or warranty is given and Application Solutions (Safety and Security) Limited assumes no liability with respect to the accuracy of such information.