

Avonic

CM60-IPU

Full HD Video USB 3.0 IP Camera

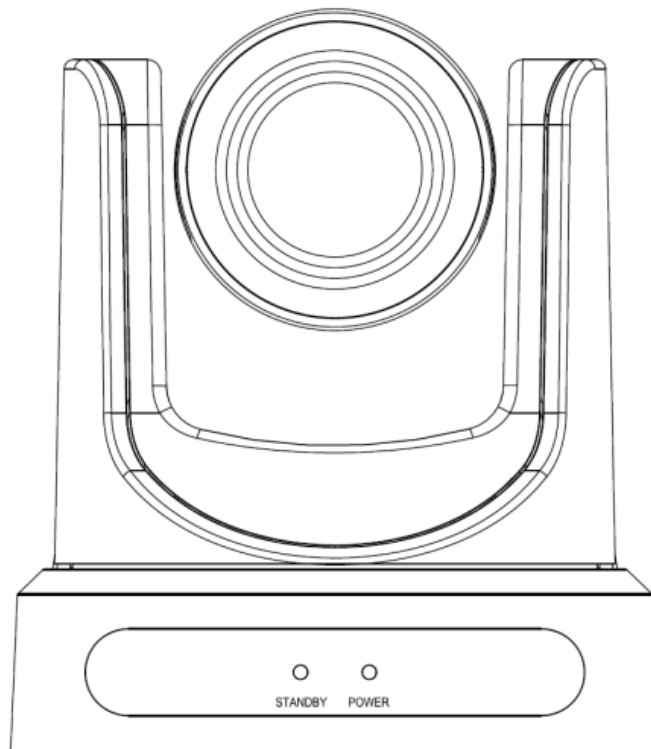

User Manual

Version 2.4

Update notes:

Special color settings for VC application

Join Avonic



[linkedin.com/company/avonic](https://www.linkedin.com/company/avonic)



Contents

Introduction	6
Congratulations	6
Safety Notes	6
Package contents	7
Accessories	7
Product Overview.....	9
Features.....	9
Main Unit.....	10
Input and Output Description	10
IR Remote Controller	12
Remote Control Shortcuts.....	Error! Bookmark not defined.
Remote Control IR channel Settings.....	Error! Bookmark not defined.
Installation	16
Connection Diagram.....	16
System Select Switch	16

Power adapter.....	17
RS232 Interface.....	18
VISCA network connection diagram.....	Error! Bookmark not defined.
RS485 network connection diagram.....	Error! Bookmark not defined.
Operation.....	21
OSD Menu.....	21
1. MENU.....	23
2. EXPOSURE.....	24
3. COLOR.....	26
4. IMAGE.....	27
5. P/T/Z.....	29
6. NOISE REDUCTION.....	30
7. SETUP.....	30
8. COMMUNICATION SETUP.....	31
9. RESTORE DEFAULT.....	32
Serial Communication Control.....	32
COM port settings.....	32
Command List.....	33
Network Function.....	34
Operating Environment.....	34
Equipment Installation.....	34

LAN Access and Control	35
Visit/Access IP Camera.....	35
TCP/UDP Control.....	37
WebGUI Homepage	37
Menu	37
Video	40
Image Setup.....	42
Audio Setup.....	43
System Setting	44
Network Setting.....	46
RTSP stream media player	48
IP Port parameters	48
Device Information	48
USB 3.0	49
Support OS	49
General software	49
Maintenance	51
Camera Maintenance	51
Unqualified Application.....	51
Troubleshooting	51
Image	51

Control	53
Contact	53
Appendix A	54
VISCA Camera Return Command List	54
VISCA Camera Control Command List	56
VISCA Query Command List	64
Pelco-D Protocol Command List	72
Pelco-P Protocol Command List	73
VISCA over IP commands	74
Appendix B Quick Start	83
Appendix C Dimensions	84

Introduction

Congratulations

Thank you for purchasing the Avonic CM60-IPU USB3.0 HD PTZ Camera. Before beginning to operate this device, please read the manual in order to make sure the best performance is obtained. Save this manual for future reference.

Safety Notes

- Installation and servicing should only be done by Qualified Service Personnel and conform to all local codes.
- This unit is designed for indoor use only and it must not be installed where exposed to water or other liquids and moisture.
- Before powering on the device, check the input power voltage carefully.
- Avoid shock and vibration when transporting and installing the device.
- Use wall mount brackets or ceiling mount brackets available at Avonic for safe installation.
- Electronic devices produce heat. Do not block the ventilation slots of the device and make sure the installation environment is well ventilated to avoid overheating.
- Before cleaning, unplug the power cable. Use a soft, damp cloth to clean the device, do not use strong or abrasive detergent to clean that will damage the device.
- If you wish to dispose this product, please contact Avonic to obtain info about the take-back procedure.

Package contents

Quantity	Description	Avonic SKU
1 pc	PTZ Camera	CM60-IP
1 pc	Power Supply 12V/A	CM-PSU
1 pc	Remote Control	CM-RC
1 pc	RS232 9-pin female to 8-pin male	CM-RS232
1 pc	USB 3.0	CM-USB3

Accessories

Wall mount in White and Black

Avonic SKU : CM-WMW

: CM-WMB



Ceiling mount in White and Black

Avonic SKU : CM-CMW

: CM-CMB



Product Overview

The Avonic CM-series cameras are designed for fixed installations. Without concessions on quality, these cameras are an affordable choice for many installations. The cameras are equipped with a Panasonic CMOS sensor combined with a glass high-quality glass lens with 20x optical zoom. Control these cameras over RS232/485 with the Avonic CM-CON100 PTZ controller or any third party controller that supports VISCA, Pelco-P/D protocols.

These high-quality conference video cameras, with resolutions up to 1080p/60 and h.265 encoded ultra-low bandwidth video streams, have adopted Panasonic's HD CMOS sensor, which produces high-quality images. The high SNR (55db) of the CMOS sensor combined with 2D and 3D noise reduction algorithms, effectively reduce the noise, even under low light conditions. Supports HDMI and CVBS output with high effective transmission distances. Using RS232/485 interface or over IP, all the parameters of the camera can be remote-controlled.

Features

- H.265 encoding support, enabling full HD 1080p/60 video stream by ultra-low bandwidth.
- Apply Panasonic's 1/2.7 inch, 2.07 million effective pixels high quality HD CMOS sensor, can reach maximum Full HD 1920 x 1080 high resolution and achieve quality image.
- The output frame rate up to 60fps in 1080P, up to 120fps output in 720P
- AAC audio encoding, better sound quality and smaller bandwidth.
- High SNR of CMOS sensor combined with 2D and 3D noise reduction algorithm,

effectively reduce the noise, even under low illumination conditions, picture can still keep clean and clear.

- HDMI output interface, effective transmission distance up to 100 meters. SD CVBS output.
- 20x Optical.
- Remote Control Using RS232/485 interface, all the parameters of the camera can be remote controlled by the high-speed communications.
- "Freeze During Preset" function, can masked image when calling the preset.
- Unique Color Settings Optimized for video conferencing.

Main Unit

Input and Output Description

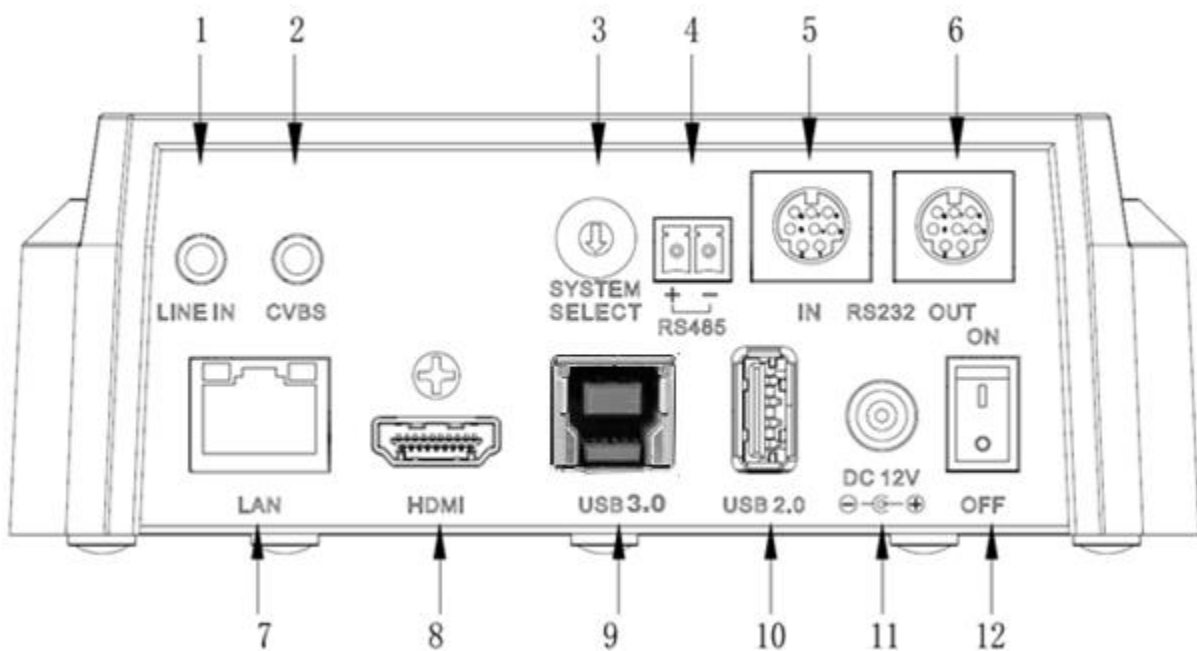

1. Audio LINE IN Interface (for audio embedding in IP stream only)
2. CVBS Interface
3. System select switch

4. RS485 interface
5. RS232 IN interface
6. RS232 OUT interface
7. Network Interface
8. HDMI Interface
9. USB 3.0 video capture device output
10. USB2.0 (update only)
11. DC 12V jack
12. Power switch

IR Remote Controller

1. Standby Button

Press this button to enter standby mode.

Press it again to enter normal mode. (Note:

Power consumption in standby mode is approximately half of the normal mode)

2. Position Buttons

To set preset or call preset

3. *Button

Used with other buttons

4. Set/Preset Buttons

Set preset: Store a preset position

[SET PRESET] + Numeric button (0-9):

Setting a corresponding numeric key preset position

5. Pan-Tilt control Buttons

Pressing the Pan-Tilt back to the middle position

6. Back buttons

Press the OSD menu return to the superior.

7. Zoom Buttons

Slow Zoom: Zoom In [+] or Zoom Out [-] slowly

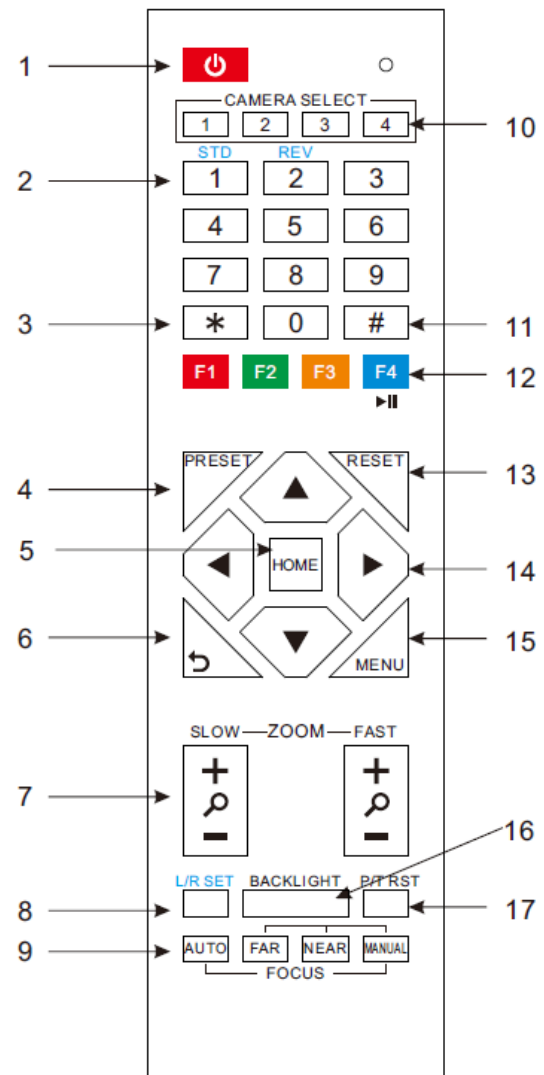

Fast Zoom: Zoom In [+] or Zoom Out [-] fast

8. 8. Pan-Tilt L/R set

Press with 1 buttons and 2 buttons setting the direction of the Pan-Tilt

L/R Set +1[STD]: set the Pan-Tilt turn the same direction as the L/R Set

L/R Set +2[REV]: set the Pan-Tilt turn the opposite direction as the L/R Set

9. 9. Focus Buttons

Used for focus adjustment.

Press [AUTO] adjust the focuses on the center of the object automatically. To adjust the focus manually. Press [MANUAL] adjust the focus on the center of the object manual

MANUAL button, and adjust it with [Far] (Focus on far object) and [NEAR] (Focus on near object)

10. Camera IR channel Select Buttons

Press the button corresponding to the camera you want to operate with the remote controller.

11. # Button

Used with other buttons

12. Set Camera IR Address Buttons

[*]+[#]+[F1]: The camera is set to IR channel 1.

[*]+[#]+[F2]: The camera is set to IR channel 2.

[*]+[#]+[F3]: The camera is set to IR channel 3.

[*]+[#]+[F4]: The camera is set to IR channel 4.

13. Clear Preset Buttons

Clear preset: Erase a preset position

[CLEAR PRESET] + Numeric button (0-9)

Or: [*]+[#]+[CLEAR PRESET]: Erase all the preset individually

14. Pan/Tilt Control Buttons

Press arrow buttons to perform panning and tilting. Press [HOME] button to face the camera back to front

15. MENU

MENU: enter or exit OSD MENU

16. BLC (Backlight Compensation) Button

BLC ON/OFF: Press this button to enable the backlight compensation. Press it again to disable the backlight compensation.(NOTE: Effective only in auto exposure mode)

Note: If a light behind the subject, the subject will become dark. In this case, press the backlight ON / OFF button. To cancel this function, press the backlight ON / OFF button.

17. Pan/Tilt reset

Preset Pan/Tilt self-test.

Remote Control Shortcuts

[*]+[#]+[1]: OSD menu default in English

[*]+[#]+[4]: Show IP address and network settings

[*]+[#]+[6]: recover the defaults

[*]+[#]+[8]: Show the camera version

[*]+[#]+[9]: set up inversion

Remote Control IR channel Settings

[*]+[#]+[F1]: The camera is set to IR channel 1.

[*]+[#]+[F2]: The camera is set to IR channel 2.

[*]+[#]+[F3]: The camera is set to IR channel 3.

[*]+[#]+[F4]: The camera is set to IR channel 4.

Installation

Connection Diagram

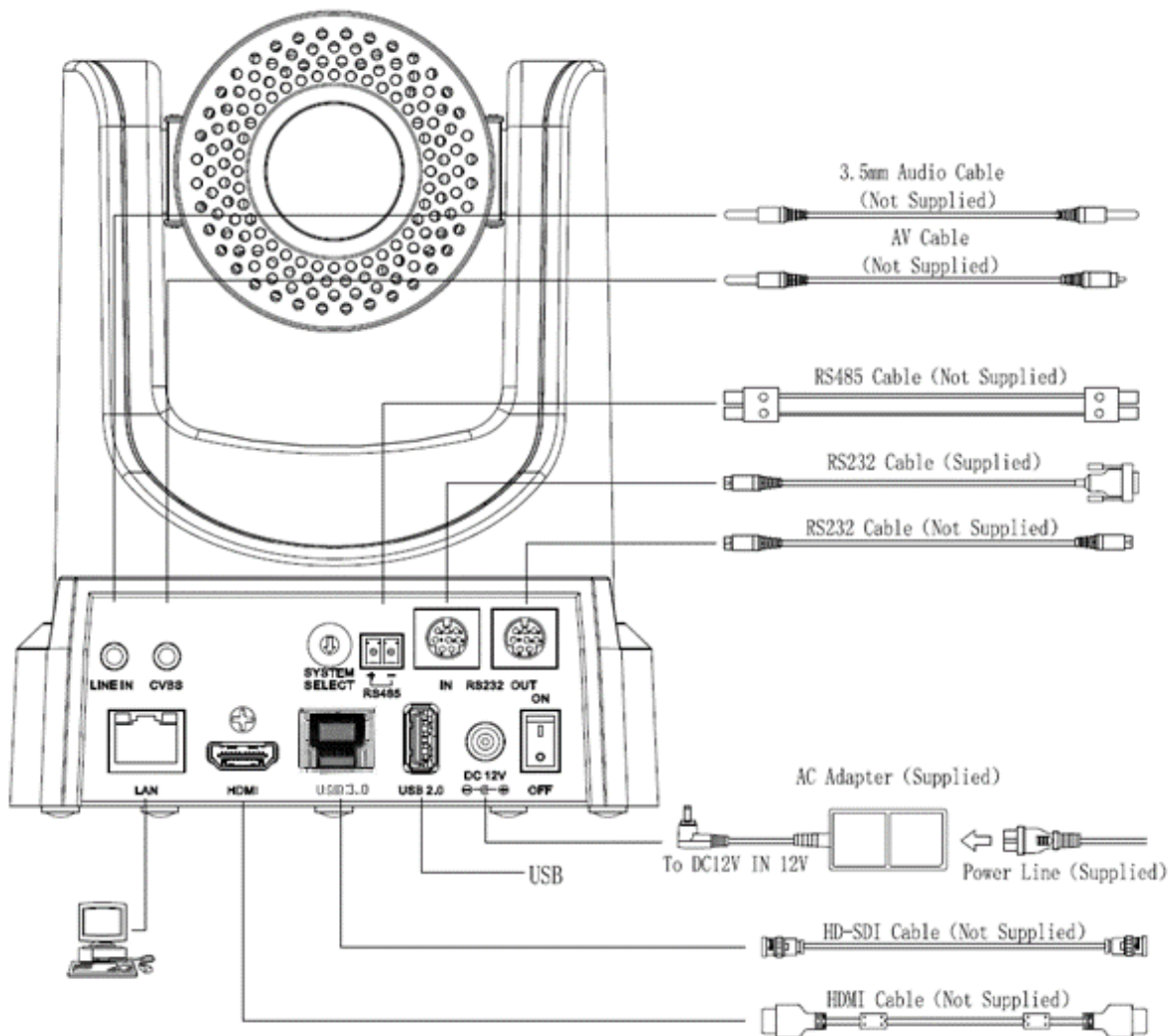

System Select Switch

Setting of the system select switch. The option of video format:

VIDEO SYSTEM			
0	1080p60	8	720p30
1	1080p50	9	720p25

	2	1080i60	A	-
	3	1080i50	B	-
	4	720p60	C	-
	5	720p50	D	576i
	6	1080p30	E	480i
	7	1080p25	F	-

CAUTION:

- a. After changing the switch, you need to restart the camera to take effect.
- b. 720 p30 and 720 p25 only under the HDMI output.

Power adapter

This equipment is equipped with a 12V/2A DC power supply. Insert the power supply according to the requirements, turn on the power switch.

RS232 Interface

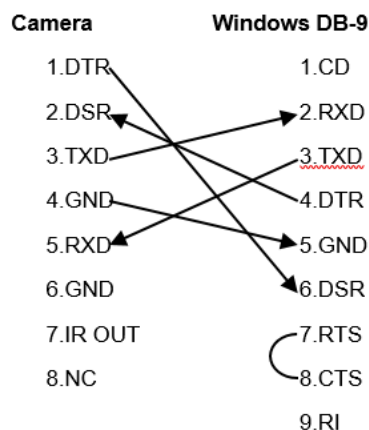
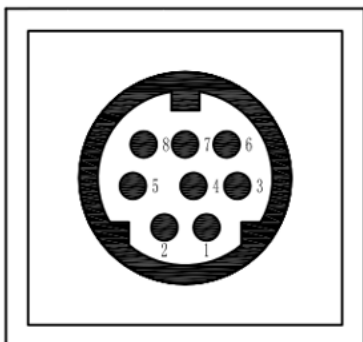

No.	Function
1	DTR
2	DSR
3	TXD
4	GND
5	RXD
6	GND
7	IR OUT
8	NC

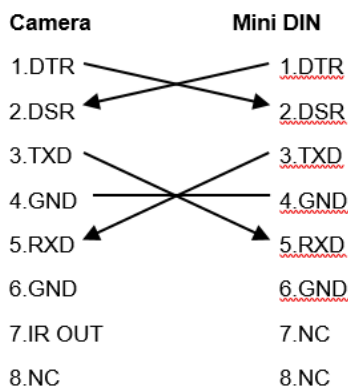

RS232 network connection diagram

This setup is for RS232 serial connection with the VISCA protocol. The Controller is connected to the RS232-IN of the first camera in the serial circuit. The RS232-OUT of the first camera is connected to the RS232-IN of the second camera and so on.

In the OSD menu under Communication Setup, the Protocol is Auto / VISCA, and Net mode is set to Serial.

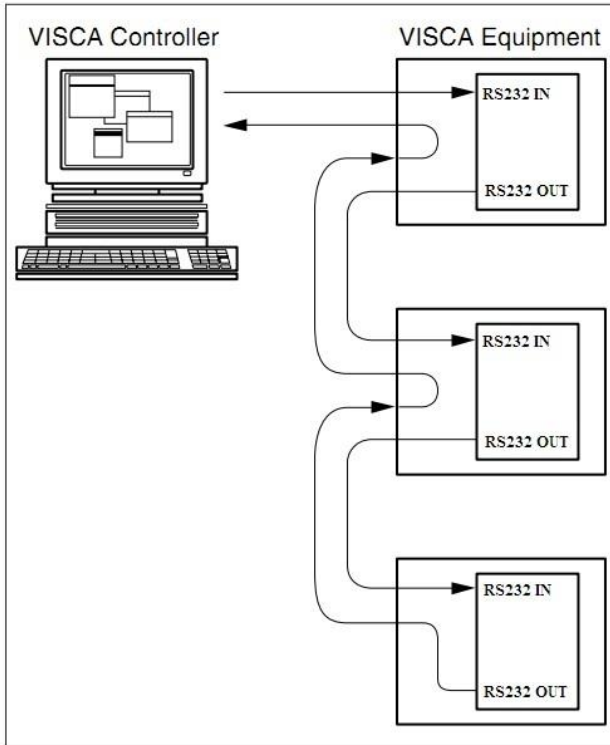

RS485 network connection diagram

The setup for RS485 is a parallel network. To connect multiple cameras by RS485, the cameras need to get attached to a 2-wire twisted pair bus that is terminated at both ends with a 120 Ω impedance resistor. The maximum length of the bus is 1200m. The maximum distance from the bus to the camera or controller is 5 meters. The cameras are connected with the 2-pin Phoenix connector. In the OSD menu under Communication Setup, Net mode is set to Paral.

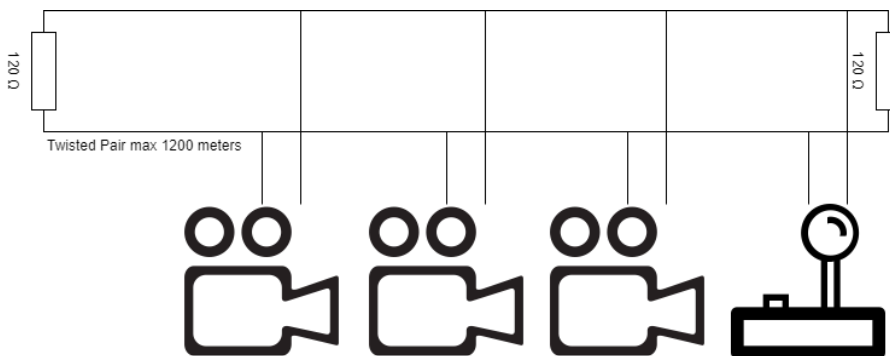

Operation

OSD Menu

9. The OSD menu can be accessed by the Remote Control or an Avonic PTZ controller. In the following pages, the navigating is described for using the IR Remote Control.

Menu Tree

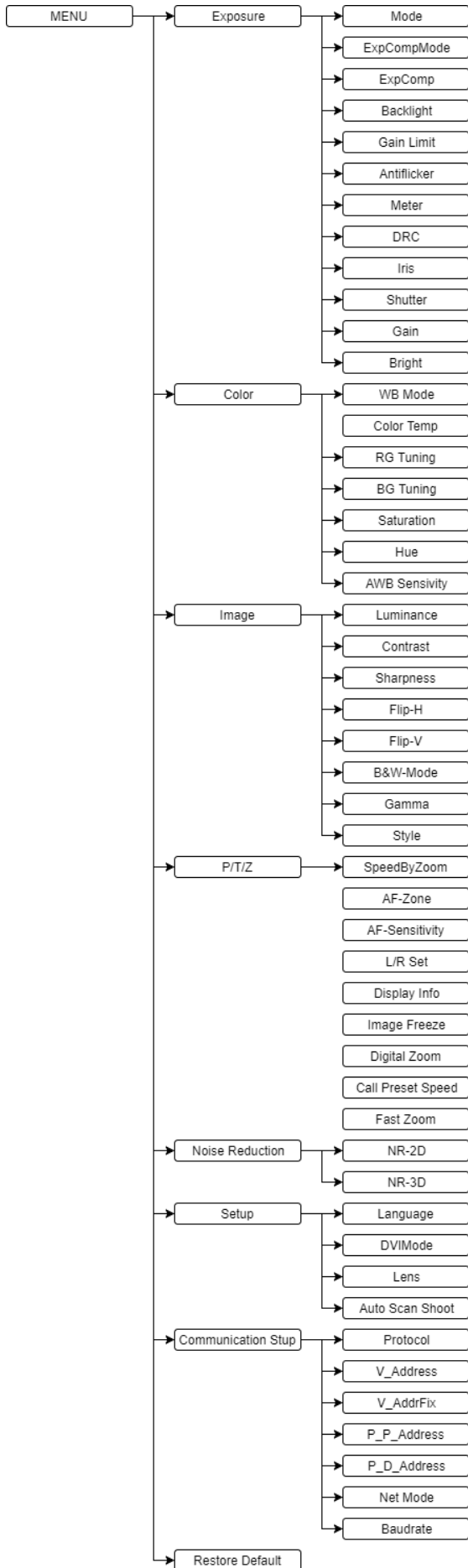

1. MENU

Press [MENU] button to display the main menu on the normal screen, using arrow button to move the cursor to the item to be set. Press the [HOME] button to enter the corresponding sub-menu.

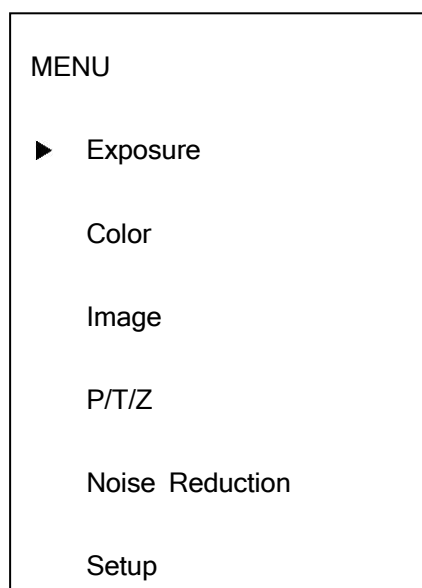

2. EXPOSURE

EXPOSURE	
▶ Mode	Auto
ExpCompMode	On
ExpComp	+3
Backlight	Off
Shutter	
Iris	
Bright	
Gain Limit	3
Meter	Average

Mode	Exposure mode. Optional items: Auto, Manual, SAE, AAE, Bright
ExpCompMode	Exposure compensation mode Optional items: On, Off (Effective only in Auto mode)
ExpComp	Exposure compensation value Optional items: -7 ~ 7(Effective only in ExpComp Mode item to On)
Backlight	Set the backlight compensation, Optional items: On, Off (Effective only in Auto mode)
Gain Limit	Maximum gain limit. Optional items: 0 ~ 15 (Effective only in Auto, AAE ,Bright mode)
Meter	Optional Items: Average, Center, Smart, Top

DRC	Dynamic Range Contrast strength, Optional items: 0 ~ 8.
Bright	Intensity control Optional items: 00 ~ 17. (Effective only in Bright mode)
Anti-Flicker	Anti-flicker. Optional items: Off, 50Hz, 60Hz (Effective only in Auto, Bright mode)
Iris	Aperture value. Optional items: F1.8, F2.0, F2.4, F2.8, F3.4, F4.0, F4.8, F5.6, F6.8, F8.0, F9.6, F11.0, Close (Effective only in Manual, AAE mode)
Shutter	Shutter value. Optional items: 1/30, 1/60, 1/90, 1/100, 1/125, 1/180, 1/250, 1/350, 1/500, 1/725, 1/1000, 1/1500, 1/2000, 1/3000, 1/4000, 1/6000, 1/10000 (Effective only in Manual, SAE mode)
Gain	Optional items: 0 ~ 7 (Effective only in Manual)

3. COLOR

COLOR	
▶ WB Mode	Auto
Color Temp	
RG Tuning	0
BG Tuning	0
RG	
BG	
Saturation	90%

WB-Mode White balance mode.

Optional items: Auto, Indoor, Outdoor, One Push, Manual, VAR

Color Temp Color Temperature.

Optional items: 2500K ~ 8000K in steps of 100 (Effective only in VAR

Mode)

RG Red gain

Optional items: 0~255 (Effective only in Manual mode)

BG Blue gain

Optional items: 0~255 (Effective only in Manual mode)

RG Tuning Red gain fine-tuning

Optional items: -10 ~ +10 (Effective only in Auto, One Push, VAR

Mode)

BG Tuning Blue gain fine-tuning

Optional items: -10 ~ +10 (Effective only in Auto, One Push, VAR

Mode)

Sat Saturation adjustment.

Optional items: 60% ~ 200%.

Hue Chroma adjustment

Optional items: 0 ~ 14

AWB sens The white balance sensitivity,

Optional items: Normal, High, Low. (Effective only in Auto Mode)

4. IMAGE

IMAGE		
▶ Luminance		6
Contrast	6	
Sharpness		1
Flip-H		Off
Flip-V		Off
B&W-Mode		Off

Luminance Brightness adjustment.

Optional items: 0 ~ 14

Contrast Contrast adjustment

Optional items: 0 ~ 14

Sharpness	Sharpness adjustment. Optional items: Auto, 0 ~ 15
Flip-H	Image flipped horizontally. Optional items: On, Off.
Flip-V	Image Flip Vertical. Optional items: On, Off
B&W-Mode	Image color. Optional items: On, Off
Gamma	Optional items: Default, 0.45, 0.5, 0.56, 0.63
Style	Optional items: Norm, Clarity (LED), Clarity, Bright, Soft, 5S, Q-Style
LDC:	Lens Distortion Correction Optional items: On, Off. 1080p60 / 1080p50 not support the lens distortion.

5. P/T/Z

P/T/Z	
▶ SpeedByZoom	On
AF-Zone	Center
AF-Sense	High
L/R Set	STD
Display info	On
Image Freeze	Off

SpeedByZoom	The depth of field scale switch, Optional items: On, Off
AF-Zone	Interested in focusing area, Optional items: Top, Center, Bottom
AF-Sense	Automatic focusing sensitivity options, Optional items: Low, Normal, High
L/R Set	Optional items: STD, REV
Display info	On, Off
Image Freeze	Optional items: On, Off
Digital Zoom	On, Off
Call Preset Speed	1 ~ 24
Fast Zoom	Optional items: On, Off

6. NOISE REDUCTION

NOISE REDUCTION		
▶ NR2D-Level		3
NR3D-Level		3
D-HotPixel		Off

NR2D-Level 2D noise reduction.

Optional items: Off, Auto, 1 ~ 5

NR3D-Level 3D noise reduction.

Optional items: Off, 1 ~ 8

D-HotPixel Dynamic bad points,

Optional items: Off, 1 ~ 5, (Removed in newer firmware versions)

7. SETUP

SETUP		
▶ Language		EN
DVI Mode		DVI
Lens		Type1
Auto scan shoot		Off

Language menu language,

Optional items: EN, Chinese, Russian

- DVI Mode Optional items: DVI, HDMI
- Lens Optional Items: Type1, Type2
- Auto Scan Shoot Optional Items: On, Off

8. COMMUNICATION SETUP

COMMUNICATION SETUP	
▶ Protocol	VISCA
V_Address	1
V_AddrFix	Off
Net Mode	Serial
P_D_Address1	
P_P_Address0	

- Protocol Control protocol type.
 - Optional items: AUTO, VISCA, PELCO-D, PELCO-P
- V_Address Protocol address, AUTO, VISCA protocol
 - Optional items: 1 ~ 7
- V_AddrFix default set to 1.
- Net Mode Optional Items:
 - Serial, for RS232 daisy chaining wiring (VISCA only)
 - Paral, for RS485 parallel wiring
- P_D_Address PELCO-D protocol
 - Optional items: 0 ~ 254

P_P_Address PELCO-P protocol

Optional items: 0 ~ 31

Baudrate Serial port baud rate.

Optional items: 2400, 4800, 9600, 38400

9. RESTORE DEFAULT

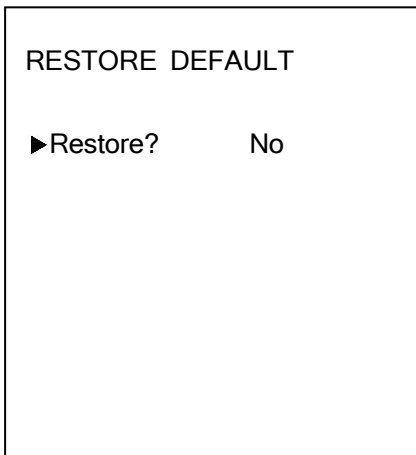

Restore Confirm restore factory settings.

Optional items: Yes, No Press [HOME] button to confirm, All parameter restore default, Include IR Remote address and VISCA Address

Serial Communication Control

COM port settings

In default working mode, the camera is able to connect to a VISCA controller with RS232C serial interface.

RS232 Communication Control:

The camera can be controlled via RS232 ,the parameters of RS232C are as follows:

- Baud rate: 2400/4800/9600 bit/s.
- Start bit: 1 bit.

- Data bit: 8 bits.
- Stop bit: 1bit.
- Parity bit: none.

RS485 Communication Control:

The camera can be controlled via RS485, Half-duplex mode:

- Baud rate: 2400/4800/9600 bit/s.
- Start bit: 1 bit.
- Data bit: 8 bits.
- Stop bit: 1bit.
- Parity bit: none.

Pan-Tilt will rotate to the maximum position of top right after the camera started, then it return to the center, the process of initialization is finished. (Note: If the position preset 0 has been stored, the position preset 0 will be called up after initialization) Then the users can control the camera with commands in the command list.

Command List

See Appendix A

Network Function

Operating Environment

- Operating System: Windows 2000/2003/XP/vista/7/8/10
- Network Protocol: TCP/IP

Equipment Installation

1. Connect IP camera to your ethernet or to your PC directly via ethernet cable.
2. The orange light of ethernet port lit on, green light flashing, and the physical connection finished.

Connection ways between IP camera and computer, as picture 1.1 and picture 1.2 shown:

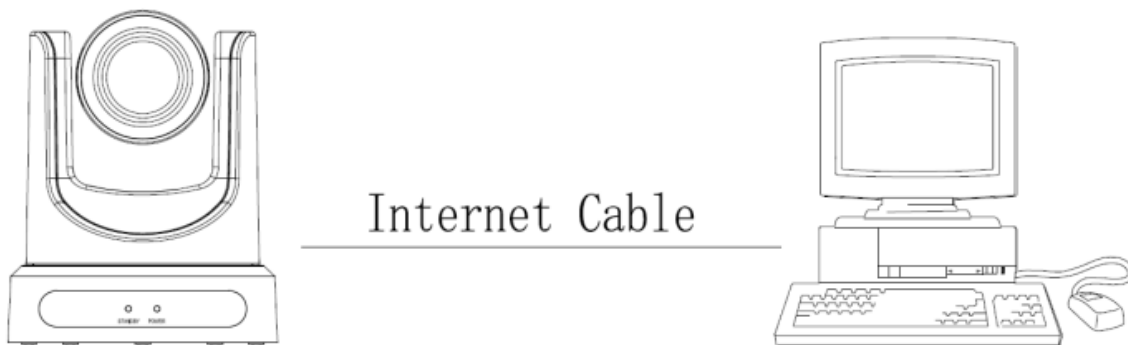

Picture 1.1 connect by ethernet cable

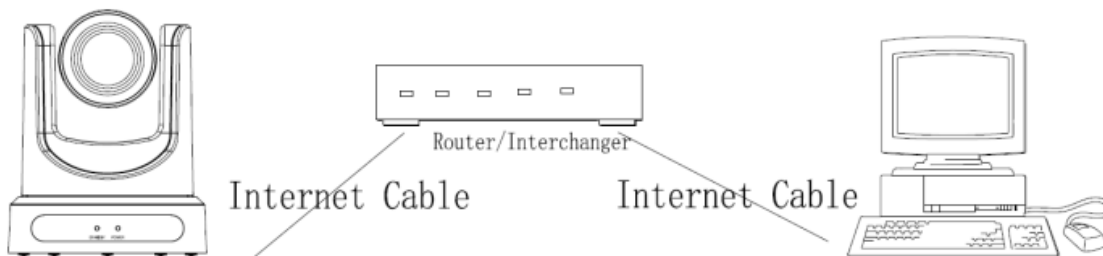

Picture 1.2 Connect by router /interchanger

LAN Access and Control

IP camera default IP address "192.168.100.88"

user "admin", password "admin".

To find camera IP, press * and # and 4 on remote controller one by one, IP address will be shown on screen.

Change IP address:

On web control page, find "Network"--->Change IP---->Click "Apply"----> Restart camera



The screenshot shows a web interface for LAN settings. The title is "Lan Settings". There are several input fields and a dropdown menu:

- IP Configuration Type: Fixed IP Address (dropdown menu)
- IP Address: 192.168.178.199
- Subnet Mask: 255.255.255.0
- Gateway: 192.168.178.1
- DNS Address: 192.168.178.1
- MAC Address: [] : [] : [] : [] : [] : []

At the bottom, there are two buttons: "Apply" and "Cancel".

Visit/Access IP Camera

Input <http://192.168.100.88> to web browser, a login window pop up, input

login name: admin

password: admin



A window like the following will appear:

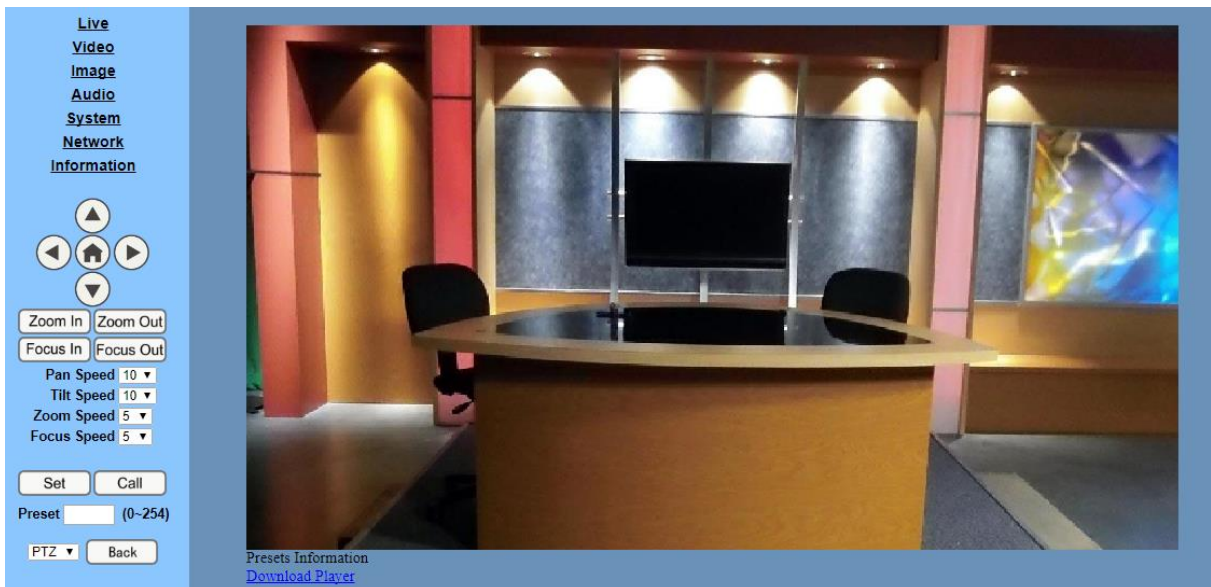

TCP/UDP Control

The Avonic IP camera is implemented with a TCP server inside. The default TCP port number is 5678. This number can be changed in the WebGUI in the Network Menu. Once the connection between client and server is set up, the client will be able to send VISCA PTZ commands to the server. The server then parses and executes the VISCA PTZ command.

The Avonic IP Camera has also implemented an UDP server inside. The UDP port number is 1259. This number cannot be changed. Once the connection between client and server is set up, the client will be able to send VISCA PTZ commands to the server. The server then parses and executes the VISCA PTZ command.

The PTZ Command Format is according to the definition of the VISCA protocol. The camera address is default set to 1. This number can be changed in the WebGUI in the Network Menu. The commands are listed in Appendix A.

WebGUI Homepage

Menu

All pages include 2 menu bars:

Real time monitoring: displaying video image Parameter setup: with function buttons

Video viewing window

Video viewing window must be same as video resolution, the bigger the resolution is, the bigger the playing area is. Double click viewing window, will show full-screen, double click

again, will return to initialized size.

1) Video playback pause button: control

real-time video pause, stop the last picture, click recoverable video again.

2) Audio control buttons: can set silent mode.

3) Full screen switch button.

PTZ Setup

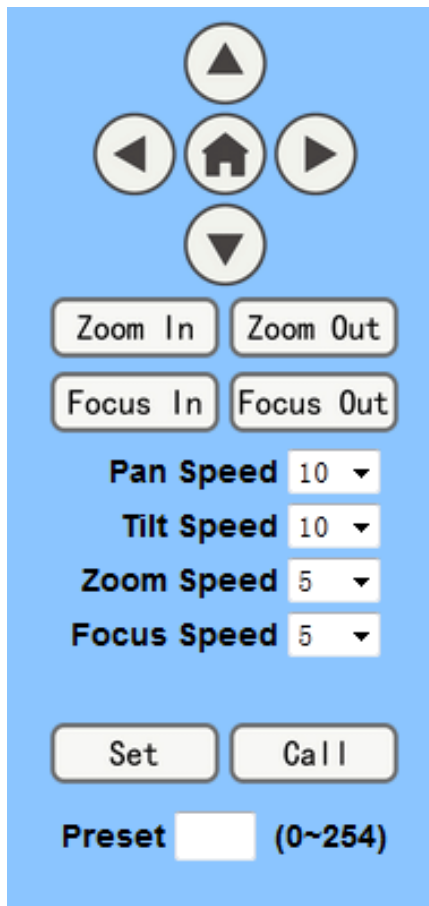

PTZ direction control box: Up, down,

left, right, home oblique button as above

Rate: Vertical speed can be chosen as

1 ~ 24, horizontal direction at the rate of 1 ~ 20.

select corresponding speed and click

direction button to realize PTZ speed up or speed down.

Zoom In/Zoom out: for zooming in or

zooming out, Focus In/ Focus Out: Focusing on distant objects or Focusing on close objects.

Set/Call: When PTZ turn to expected

position, can set up a number of preset that user want. click "Set" button, when PTZ turn to other position, click "Call" button, PTZ turn back to preset position.

Language selection

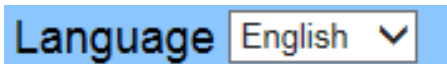

Available options are: Chinese/English/Russian

Video

Video Settings

Video Format:

Encode Level:

First stream

Encode Protocol:

Resolution:

Bit Rate: (32~20480) kbps

Frame Rate: fps

I Key Frame Interval: (2~150)

Bit Rate Control: CBR VBR

Fluctuate Level:

Slice Split Enable: On Off

Split Mode: Fixed blocks Fixed bytes

Slice Size: blocks/bytes

Second stream

Encode Protocol:

Resolution:

Bit Rate: (32~6144) kbps

Frame Rate: fps

I Key Frame Interval: (2~150)

Bit Rate Control: CBR VBR

Fluctuate Level:

Slice Split Enable: On Off

Split Mode: Fixed blocks Fixed bytes

Slice Size: blocks/bytes

Video Format : 50HZ(PAL) 60HZ(NTSC) Dial priority

Encode Level : baseline, mainprofile, highprofile

1st and 2nd stream:

Resolution : First stream support 1920x1080, 1280x720,1024x576,

Second stream support 640x360,720x576, 320x180

Bit Rate : User can assign bit flow/stream,

Frame rate : User can specify the size of the frame rate

I key frame interval : Set interval between 2 I frames

Bit Rate control : Constant bit rate or Variable bit rate

Fluctuate Level : Restrain the fluctuation magnitude of variable rate, grade 1 ~ 6

Slice Split Enable : On, Off

Split Mode :

Slice Size :

Setting Tips

The bigger resolution is, the clearer the image will be, more network bandwidth will be taken.

Bit Rate User can assign bit flow/stream, normally speaking, the bigger bit flow is, the clearer the image will be. The bit allocation must combine with network bandwidth, when the network bandwidth is too narrow and the allocated bit flow is too big, will cause video signal flow not to be transmitted normally, the video effect will be worse.

Frame rate : User can specify the size of the frame rate, generally, the frame rate greater, the image more smooth; Frame rate is smaller, the more sense of beating.

I key frame interval: Set interval between 2 I frame, the bigger interval is, the response will be lower from viewing window.

Bit Rate control : Constant bit rate Variable bit rate

Fluctuate level Restrain the fluctuation magnitude of variable rate, grade 1 ~ 6

Image Setup

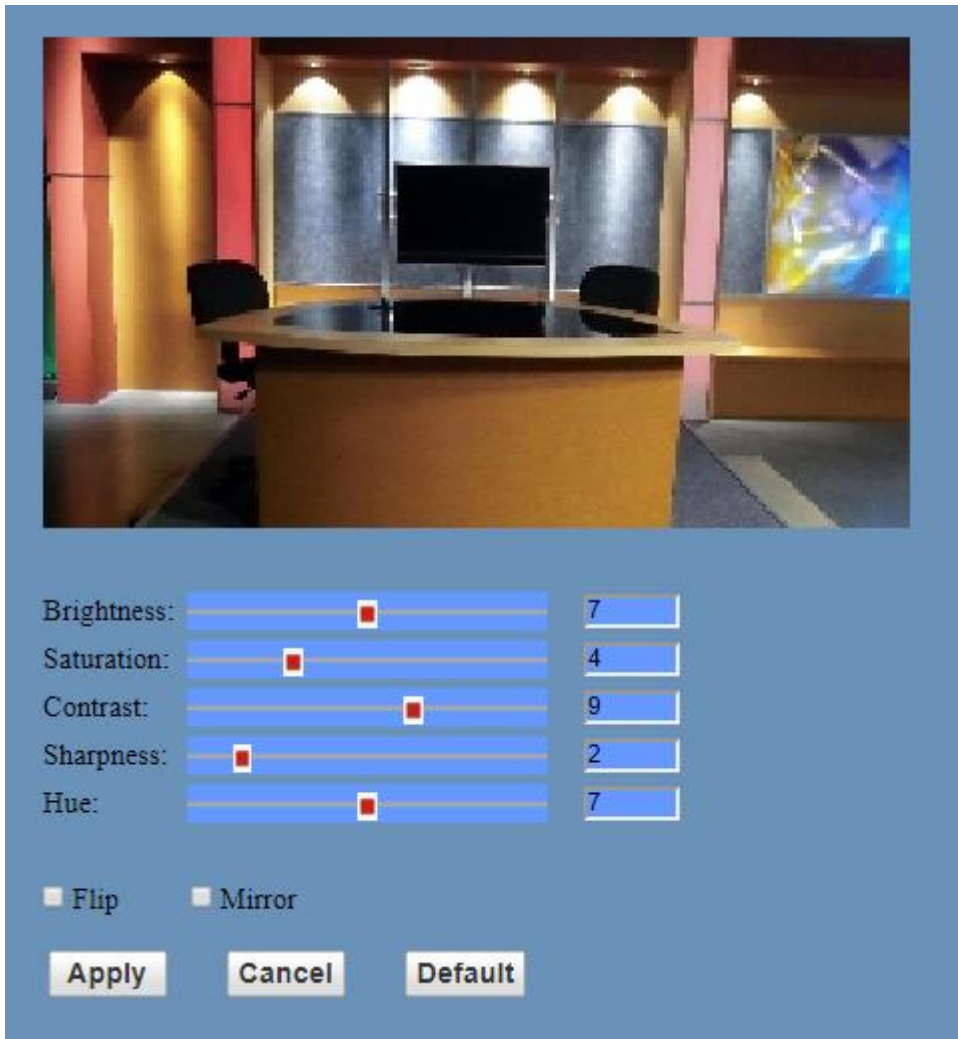

Brightness

Image bright 0~14, slider control, on the right shows the corresponding numerical. Default 6.

Saturation

Saturation 0~14, slider control, on the right shows the corresponding numerical. Default 3.

Contrast

Contrast 0~14, slider control, on the right shows the corresponding numerical. Default 6.

Sharpness

Sharpness 0~15, slider control, on the right shows the corresponding numerical. Default 1.

Hue

Hue 0~14, slider control, on the right shows the corresponding numerical. Default 7.

Flip & Mirror

Tick Flip to realize image upside down, tick mirror to realize image around the mirror. Default not tick.

Button

Adjusting the parameters, press "apply" button to save, press "cancel" button to cancel the adjustment of the parameters, press "default" button obtain the default value.

Audio Setup

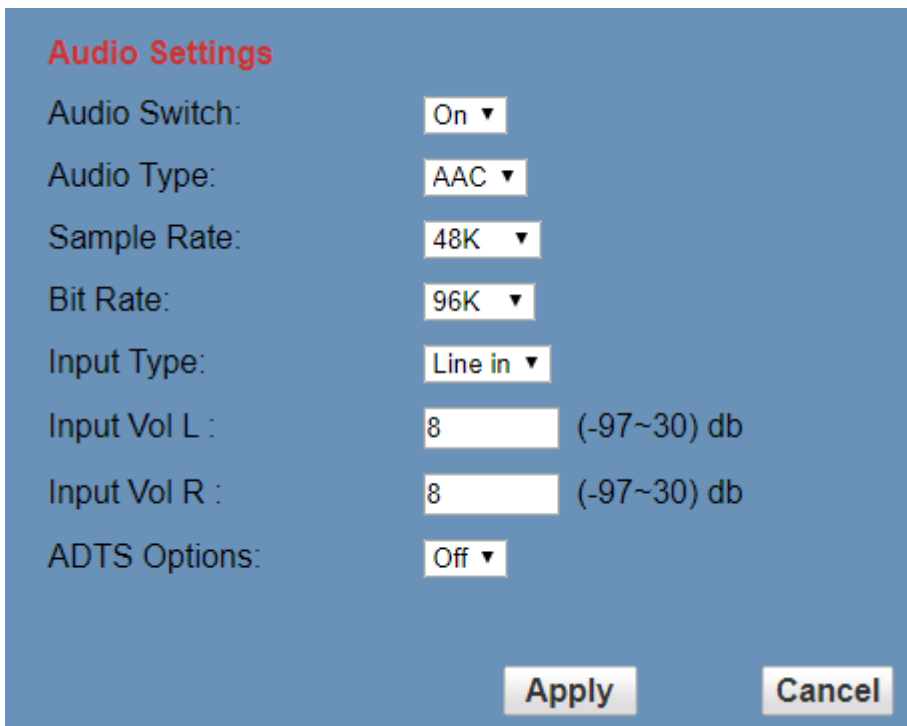

Audio Settings

Audio Switch: On ▾

Audio Type: AAC ▾

Sample Rate: 48K ▾

Bit Rate: 96K ▾

Input Type: Line in ▾

Input Vol L : 8 (-97~30) db

Input Vol R : 8 (-97~30) db

ADTS Options: Off ▾

Apply Cancel

Audio Switch (on off)

Audio Type (AAC)

Sample rate (44.1K 48K)

Bit rate (96k,128k,256k)

Input Type (line in only)

Input Vol. L The volume of the left channel

Input Vol. R The volume of the right channel

ADTS Options (On Off)

System Setting

Initialize
Work Mode: RTSP ▼
Reboot: Reboot

User
UserName: admin
Passwd:
Guest: guest
Passwd:

Apply Cancel

Work Mode

Work Mode RTSP

Reboot

Click the "Reboot" button, system restart.

User and password

The user can modify the password (letters and numbers only)

Apply / Cancel

Modify password and click the "apply" button to the login page, press "cancel" button to

cancel password change.

Network Setting

Lan Settings

IP Configuration Type: Dynamic IP Address

IP Address: 192.168.178.199

Subnet Mask: 255.255.255.0

Gateway: 192.168.178.1

DNS Address: 192.168.178.1

MAC Address: : : : : : :

Apply Cancel

Port Settings

HTTP Port number: 80 (80)

RTSP Port: 554 (554)

PTZ Port: 65535 (5678)

Control Protocol Settings

Visca Address: 1 (1~7)

Pelco-D Address: 0 (0~255)

Pelco-P Address: 0 (0~31)

RTMP Settings

First stream: On Off Video Audio

MRL: rtmp://192.168.100.138/live/stream0

Second stream: On Off Video Audio

MRL: rtmp://192.168.100.138/live/stream1

RTSP Settings

RTSP Auth: On Off

ONVIF Settings

ONVIF: On Off

ONVIF Auth: On Off

Multicast Settings

Multicast: On Off

Address: 224.1.2.3

Port: 1024

SDK Settings

Active Connection: On Off

Address: 192.168.100.138

Port: 70000

NTP Settings

NTP time sync: On Off

Server address:

Time interval: 1440 minutes

Main time show: On Off

Position: X 0 Y 0 (0~100)

Sub time show: On Off

Position: X 0 Y 0 (0~100)

Apply Cancel

Lan Settings

Default the IP address is 192.168.100.88, The MAC address can be modified.

Port Settings

HTTP Port

IP address identifies the network device, the device can run multiple web applications, each network program using network port to transmit data, so data transmission to be carried out between the port and port. Port setting is to set up WEB SERVER program using which port to transmit. When port mapping, need to be consistent with the port number(default port: 80)

RTSP Port

IP camera support RTSP protocol, use the VLC tools broadcast.

PTZ Port

Support PTZ protocol, default port: 5678.

Control Protocol Setting

Setting camera control communication protocol, include Visca address, Pelco-D address, Pelco-P address.

RTMP Setting

Setting the camera stream, can set up two stream, in the two stream selection control code stream of "On", "Off", "Video", "Audio", etc.

RTSP Setting

Setting IP camera RTST protocol of "On", "Off".

ONVIF Setting

Setting the ONVIF protocol and ONVIF authorization "On", "Off".

Multicast Setting

Setting multicast "On", "Off", and multicast address (default address 224.1.2.3) and port
(default 6688)

Apply / Cancel

Modify network parameters then press "Apply" button to modify network parameters, press
"Cancel" button to cancel network parameters. A reboot is necessary to let the changes take
effect. Go to the System menu and press Reboot button.

RTSP stream media player

rtsp://ip: port number/1 (First stream);

rtsp://ip: port number/2 (Second stream).

RTSP port number default 554.

IP Port parameters

HTTP Port range : 80; 1024-65535 (default 80)

RTSP Port range : 554; 1024-65535 (default 554)

PTZ Port range : 1024-65535 (default 5678)

Multicast Port range : 1024-65535 (default 6688)

Device Information

Show the current device information, as shown below.

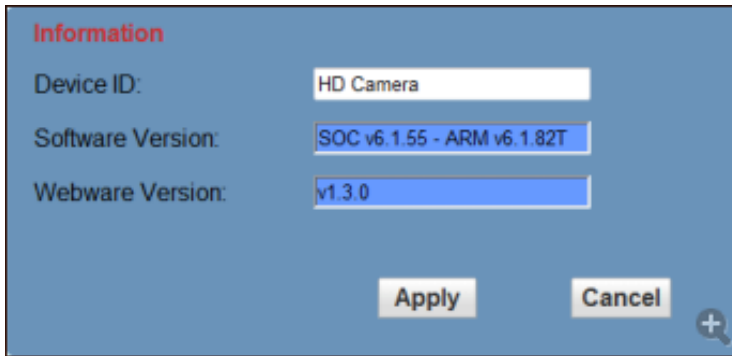

USB 3.0

Camera support UVC protocol, compatible USB2.0 & USB3.0.

USB3.0 support 1920x1080p/60 max output.

USB2.0 support 960x540p/60 max output.

The OS will recognize the camera as USB Video Capture Device according to UVC 1.0

Support OS

Windows XP/2003/VISTA/7/8 and another system, Linux, Mac OS

General software

Windows: AMCAP, VLC, Debut Video Capture, etc.

Linux: V412 software driver and VLC media player, etc.

Mac OS: FaceTime. iChat, Photo Booth and Debut Video Capture, etc.

Maintenance

Camera Maintenance

- If camera will not be used for a long time, please turn off the power switch, disconnect AC power cord of AC adaptor to the outlet.
- Use soft cloth or tissue to clean the camera cover.
- Please use the soft dry cloth to clean the lens. If the camera is very dirty, clean it with diluted neuter detergent. Do not use any type of solvents, which may damages the surface.

Unqualified Application

- No shooting extreme bright object for a long period of time, such as sunlight, light sources, etc.
- No operating in unstable lighting conditions, otherwise image will be flickering.
- No operating close to powerful electromagnetic radiation, such as TV or radio transmitters, etc.

Troubleshooting

Image

- No image

1. Check whether the power cord is connected, voltage is OK, POWER lamp is light.

2. Check whether the camera can self-test after startup.
3. Check the BOTTOM switch and make sure the two switches are both set OFF.
4. Check video cable is connected correctly.

- Abnormal display of image

Check video cable is connected correctly.

- Image dithering even at widest zoom position

1. Check whether camera is fixed correctly.
2. Make sure if there are something like vibration machine or other things nearby.

- Browser has no video image

When IPC by a web browser, it needs to install plug-in.

- Unable to access IP Camera by web browser.

1. Access to the network with PC can test whether network works, in this way to get rid of cable failure, network failure caused by PC virus until the PC can be Ping.
2. Disconnect IP Camera with network, IP Camera and PC are connected, according to the proper operations to re-set the IP address.
3. Check the server's IP address and subnet mask and gateway address.
4. MAC addresses conflict.
5. Web port is occupied by other devices.
 - When modify IP address in an incorrect way cause the wrong IP address or forget web passwords, press the IR remote controller "[*]+[#]+[Manual]" to restore the default value (Default IP: 192.168.100.88 Default username: admin Default password: admin)

Control

- IR remote controller cannot control the camera

1. Change the battery
2. Check the camera working mode.
3. Check IR address of the Remote Commander is set correctly.

- Serial communication cannot control the camera

1. Check the camera working mode.
2. Check control cable is connected correctly.

Contact

For any questions or suggestions, contact the reseller or the local distributor of Avonic. Find the local distributor on the website of Avonic.

For the recent manual or datasheet, look at the Avonic website.

www.avonic.eu

Appendix A

VISCA Camera Return Command List

x= Camera Address

y= Socket Number

z = Camera Address + 8

Command	Function	Command Package	Note
AddressSet	Broadcast	88 30 01 FF	Address setting
IF_Clear	Broadcast	88 01 00 01 FF	I/F Clear
CAM_Power	On	8x 01 04 00 02 FF	Power ON/OFF
	Off	8x 01 04 00 03 FF	
CAM_Zoom	Stop	8x 01 04 07 00 FF	p = 0(low) - 7(high)
	Tele(Standard)	8x 01 04 07 02 FF	
	Wide(Standard)	8x 01 04 07 03 FF	
	Tele(Variable)	8x 01 04 07 2p FF	
	Wide(Variable)	8x 01 04 07 3p FF	
	Direct	8x 01 04 47 0p 0q 0r 0s FF	pqrs: Zoom Position

Command	Function	Command Package	Note
---------	----------	-----------------	------

ACK/Completion Messages	ACK	z0 4y FF (y: Socket No.)	Return when the command is accepted.
	Completion	z0 5y FF (y: Socket No.)	Return when the command has been executed.

Command	Function	Command Package	Note
Error Messages	Syntax Error	z0 60 02 FF	Returned when the command format is different or when a command with illegal command parameters is accepted.
	Command Buffer Full	z0 60 03 FF	Indicates that two sockets are already being used(executing two commands) and the command could not be accepted when received.
	Command Canceled	z0 6y 04 FF (y: Socket No.)	Returned when a command which is being executed in a socket specified by the cancel command is canceled.

		The completion message for the command is not returned.
No Socket	z0 6y 05 FF (y: Socket No.)	Returned when no command is executed in a socket specified by the cancel command, or when an invalid socket number is specified.
Command Not Executable	z0 6y 41 FF (y: Execution command Socket No. Inquiry command: 0)	Returned when a command cannot be executed due to current conditions. For example, when commands controlling the focus manually are received during auto focus.

VISCA Camera Control Command List

Command	Function	Command Package	Notes
CAM_Focus	Stop	8x 01 04 08 00 FF	
	Far(Standard)	8x 01 04 08 02 FF	

	Near(Standard)	8x 01 04 08 03 FF	
	Far(Variable)	8x 01 04 08 2p FF	p = 0(low) - 7(high)
	Near(Variable)	8x 01 04 08 3p FF	
	Direct	8x 01 04 48 0p 0q 0r 0s FF	pqrs: Focus Position
	Auto Focus	8x 01 04 38 02 FF	AF On
	Manual Focus	8x 01 04 38 03 FF	AF Off
	Auto/Manual	8x 01 04 38 10 FF	AF Toggle On/Off
CAM_ZoomFocus	Direct	8x 01 04 47 0p 0q 0r 0s 0t 0u 0v 0w FF	pqrs: Zoom Position tuvw: Focus Position
CAM_WB	Auto	8x 01 04 35 00 FF	Normal Auto
	Indoor mode	8x 01 04 35 01 FF	Indoor mode
	Outdoor mode	8x 01 04 35 02 FF	Outdoor mode
	OnePush mode	8x 01 04 35 03 FF	One Push WB mode
	Manual	8x 01 04 35 05 FF	Manual Control mode
	OnePush trigger	8x 01 04 10 05 FF	One Push WB Trigger
CAM_RGain	Reset	8x 01 04 03 00 FF	Manual Control of R
	Up	8x 01 04 03 02 FF	Gain
	Down	8x 01 04 03 03 FF	
	Direct	8x 01 04 43 00 00	pq: R Gain

		0p 0q FF	
CAM_Bgain	Reset	8x 01 04 04 00 FF	Manual Control of B
	Up	8x 01 04 04 02 FF	Gain
	Down	8x 01 04 04 03 FF	
	Direct	8x 01 04 44 00 00	pq: B Gain
		0p 0q FF	
CAM_AE	Full Auto	8x 01 04 39 00 FF	Automatic Exposure mode
	Manual	8x 01 04 39 03 FF	Manual Control mode
	Shutter priority	8x 01 04 39 0A FF	Shutter Priority Automatic Exposure mode
	Iris priority	8x 01 04 39 0B FF	Iris Priority Automatic Exposure mode
	Bright	8x 01 04 39 0D FF	Bright Mode(Manual control)
CAM_SlowShutter	AutoSlowShutterLimit	8x 01 04 2A 0p 00 FF	
CAM_Iris	Reset	8x 01 04 0B 00 FF	Iris Setting
	Up	8x 01 04 0B 02 FF	
	Down	8x 01 04 0B 03 FF	
	Direct	8x 01 04 4B 00 00	pq: Iris Position

		0p 0q FF	
CAM_Gain	Reset	8x 01 04 0C 00 FF	Gain Setting
	Up	8x 01 04 0C 02 FF	
	Down	8x 01 04 0C 03 FF	
	Direct	8x 01 04 0C 00 00	pq: Gain Position
		0p 0q FF	
	Gain Limit	8x 01 04 2C 0p FF	p: Gain Position
CAM_Bright	Reset	8x 01 04 0D 00 FF	Bright Setting
	Up	8x 01 04 0D 02 FF	
	Down	8x 01 04 0D 03 FF	
	Direct	8x 01 04 0D 00 00	pq: Bright Position
		0p 0q FF	
CAM_ExpComp	On	8x 01 04 3E 02 FF	Exposure
	Off	8x 01 04 3E 03 FF	Compensation On/Off
	Reset	8x 01 04 0E 00 FF	Exposure
	Up	8x 01 04 0E 02 FF	Compensation
	Down	8x 01 04 0E 03 FF	Amount Setting
	Direct	8x 01 04 4E 00 00	pq: ExpComp
		0p 0q FF	Position
CAM_BackLight	On	8x 01 04 33 02 FF	Back Light
	Off	8x 01 04 33 03 FF	Compensation On/Off
CAM_NR(2D)Mode	Auto	8x 01 04 50 02 FF	ND2D Auto/Manual

	Manual	8x 01 04 50 03 FF	
CAM_NR(2D)Level	-	8x 01 04 53 0p FF	p: NR Setting (0: Off, level 1 to 5)
CAM_NR(3D)Level	-	8x 01 04 54 0p FF	p: NR Setting (0: Off, level 1 to 8)
CAM_Flicker	-	8x 01 04 23 0p FF	p: Flicker Settings (0: Off, 1: 50Hz, 2: 60Hz)
CAM_DHotPixel	-	8x 01 04 56 0p FF	p: Dynamic Hot Pixel Setting (0: Off, level 1 to 6)
CAM_ApertureMode	Auto	8x 01 04 05 02 FF	Sharpness Auto
(sharpness)	Manual	8x 01 04 05 02 FF	Sharpness Manual
CAM_Aperture	Reset	8x 01 04 02 00 FF	Aperture Control
(sharpness)	Up	8x 01 04 02 02 FF	
	Down	8x 01 04 02 03 FF	
	Direct	8x 01 04 42 00 00 0p 0q FF	pq: Aperture Gain
CAM_PictureEffect	Off	8x 01 04 63 00 FF	Picture Effect Setting
	B&W	8x 01 04 63 04 FF	
CAM_Memory	Reset	8x 01 04 3F 00 pp FF	pp: Memory Number(=0 to 127)

	Set	8x 01 04 3F 01 pp	
		FF	
	Recall	8x 01 04 3F 02 pp	
		FF	
CAM_LR_Reverse	On	8x 01 04 61 02 FF	Image Flip Horizontal
	Off	8x 01 04 61 03 FF	On/Off
CAM_PictureFlip	On	8x 01 04 66 02 FF	Image Flip Vertical
	Off	8x 01 04 66 03 FF	On/Off
CAM_RegisterValue	-	8x 01 04 24 mn 0p 0q FF	mm: Register No. (=00-7F) pp: Register Value (=00-7F)
CAM_ColorGain	Diret	8x 01 04 49 00 00	p: Color Gain setting
		00 0p FF	0h (60%) to Eh -200%
SYS_Menu	Off	8x 01 06 06 03 FF	Turns off the menu screen
Pan_tiltDrive	Up	8x 01 06 01 VV WW	VV: Pan speed 0x01
		03 01 FF	(low speed) to 0x18
	Down	8x 01 06 01 VV WW	(high speed)
		03 02 FF	
	Left	8x 01 06 01 VV WW	WW: Tilt speed 0x01
		01 03 FF	(low speed) to 0x14

	Right	8x 01 06 01 VV WW (high speed)	
		02 03 FF	
	Upleft	8x 01 06 01 VV WW	YYYY: Pan Position
		01 01 FF	
	Upright	8x 01 06 01 VV WW	ZZZZ: Tilt Position
		02 01 FF	
	DownLeft	8x 01 06 01 VV WW	
		01 02 FF	
	DownRight	8x 01 06 01 VV WW	
		02 02 FF	
	Stop	8x 01 06 01 VV WW	
		03 03 FF	
	AbsolutePosition	8x 01 06 02 VV WW	
		0Y 0Y 0Y 0Y 0Z 0Z	
		0Z 0Z FF	
	RelativePosition	8x 01 06 03 VV WW	
		v0Y 0Y 0Y 0Y 0Z 0Z	
		0Z 0Z FF	
	Home	8x 01 06 04 FF	
	Reset	8x 01 06 05 FF	
Pan_tiltLimitSet	LimitSet	8x 01 06 07 00 0W	W: 1 UpRight 0: DownLeft YYYY: Pan
		0Y 0Y 0Y 0Y 0Z 0Z	

		0Z 0Z FF	Limit Position
	LimitClear	8x 01 06 07 01 0W 07 0F 0F 0F 07 0F 0F 0F FF	ZZZZ: Tilt Position
CAM_AFSensitivity	High	8x 01 04 58 01 FF	AF Sensitivity
	Normal	8x 01 04 58 02 FF	High/Normal/Low
	Low	8x 01 04 58 03 FF	
CAM_SettingReset	Reset	8x 01 04 A0 10 FF	Reset Factory Setting
CAM_Brightness	Direct	8x 01 04 A1 00 00	pq: Brightness
		0p 0q FF	Position
CAM_Contrast	Direct	8x 01 04 A2 00 00	pq: Contrast Position
		0p 0q FF	
CAM_Flip	Off	8x 01 04 A4 00 FF	
	Flip-H	8x 01 04 A4 01 FF	
	Flip-V	8x 01 04 A4 02 FF	
	Flip-HV	8x 01 04 A4 03 FF	Single Command For Video Flip
CAM_SettingSave	Save	8x 01 04 A5 10 FF	Save Current Setting
CAM_Iridix	Direct	8x 01 04 A7 00 00	pq: Iridix Position
		0p 0q FF	
CAM_AWBSensitivity	High	8x 01 04 A9 00 FF	High
	Normal	8x 01 04 A9 01 FF	Normal

	Low	8x 01 04 A9 02 FF	Low
CAM_AFZone	Top	8x 01 04 AA 00 FF	AF Zone weight
	Center	8x 01 04 AA 01 FF	select
	Bottom	8x 01 04 AA 02 FF	
CAM_ColorHue	Direct	8x 01 04 4F 00 00	p: Color Hue setting
		00 0p FF	0h (- 14 dgree) to Eh (+14 degrees)

VISCA Query Command List

Command	Command Package	Return Package	Note
CAM_PowerInq	8x 09 04 00 FF	y0 50 02 FF	On
		y0 50 03 FF	Off(Standby)
		y0 50 04 FF	Internal power circuit error
CAM_ZoomPosInq	8x 09 04 47 FF	y0 50 0p 0q 0r 0s FF	pqrs: Zoom Position
CAM_FocusAFMode Inq	8x 09 04 38 FF	y0 50 02 FF	Auto Focus
		y0 50 03 FF	Manual Focus
CAM_FocusPosInq	8x 09 04 48 FF	y0 50 0p 0q 0r 0s FF	pqrs: Focus Position
CAM_WBModelInq	8x 09 04 35 FF	y0 50 00 FF	Auto
		y0 50 01 FF	Indoor mode
		y0 50 02 FF	Outdoor mode

		y0 50 03 FF	OnePush mode
		y0 50 05 FF	Manual
CAM_RGainInq	8x 09 04 43 FF	y0 50 00 00 0p 0q FF	pq: R Gain
CAM_BGainInq	8x 09 04 44 FF	y0 50 00 00 0p 0q FF	pq: B Gain
CAM_AEModeInq	8x 09 04 39 FF	y0 50 00 FF	Full Auto
		y0 50 03 FF	Manual
		y0 50 0A FF	Shutter priority
		y0 50 0B FF	Iris priority
		y0 50 0D FF	Bright
CAM_ShutterPosInq	8x 09 04 4A FF	y0 50 00 00 0p 0q FF	pq: Shutter Position
CAM_IrisPosInq	8x 09 04 4B FF	y0 50 00 00 0p 0q FF	pq: Iris Position
CAM_BrightPosInq	8x 09 04 4D FF	y0 50 00 00 0p 0q FF	pq: Bright Position
CAM_ExpCompMod elnq	8x 09 04 3E FF	y0 50 02 FF	On
		y0 50 03 FF	Off
CAM_ExpCompPosInq	8x 09 04 4E FF	y0 50 00 00 0p 0q FF	pq: ExpComp Position
CAM_BacklightMode Inq	8x 09 04 33 FF	y0 50 02 FF	On
		y0 50 03 FF	Off
CAM_Nosise2DMode Inq	8x 09 04 50 FF	y0 50 02 FF	Auto Noise 2D
		y0 50 03 FF	Manual Noise 3D
CAM_Nosise2DLevel	8x 09 04 53 FF	y0 50 0p FF	Noise Reduction (2D) p: 0 to 5
CAM_Noise3DLevel	8x 09 04 54 FF	y0 50 0p FF	Noise Reduction (3D)

			p: 0 to 8
CAM_FlickerModelnq	8x 09 04 55 FF	y0 50 0p FF	p: Flicker Settings(0: OFF, 1: 50Hz, 2: 60Hz)
CAM_ApertureModelnq(Sharpness)	8x 09 04 05 FF	y0 50 02 FF	Auto Sharpness
		y0 50 03 FF	Manual Sharpness
CAM_ApertureInq(Sharpness)	8x 09 04 42 FF	y0 50 00 00 0p 0q FF	pq: Aperture Gain
CAM_PictureEffectModelnq	8x 09 04 63 FF	y0 50 02 FF	Off
		y0 50 04 FF	B&W
CAM_MemoryInq	8x 09 04 3F FF	y0 50 0p FF	p: Memory number last operated.
SYS_MenuModelnq	8x 09 06 06 FF	y0 50 02 FF	On
		y0 50 03 FF	Off
CAM_LR_Reverselnq	8x 09 04 61 FF	y0 50 02 FF	On
		y0 50 03 FF	Off
CAM_PictureFlipInq	8x 09 04 66 FF	y0 50 02 FF	On
		y0 50 03 FF	Off
CAM_RegisterValueInq	8x 09 04 24 mm FF	y0 50 0p 0p ff	mm: Register No. (00 to FF) pp: Register Value (00 to FF)
CAM_ColorGainInq	8x 09 04 49 FF	y0 50 00 00 00 0p FF	p: Color Gain setting

			0h (60%) to Eh (200%)
CAM_IDInq	8x 09 04 22 FF	y0 50 0p 0q 0r 0s FF	pqrs: Camera ID
CAM_VersionInq	8x 09 00 02 FF	y0 50 ab cd mn pq rs tu vw FF	ab: Factory Code cd: Hardware Version mnpq: ARM Version rstu: FPGA Version vw: Camera model 01: C Type 02: M Type 03: S Type
VideoSystemInq	8x 09 06 23 FF	y0 50 00 FF	1920x1080i60
		y0 50 01 FF	1920x1080p30
		y0 50 02 FF	1280x720p60
		y0 50 04 FF	NTSC
		y0 50 05 FF	NTSC
		y0 50 06 FF	NTSC
		y0 50 07 FF	1920x1080p60
		y0 50 08 FF	1920x1080i50
		y0 50 09 FF	1920x1080p25
		y0 50 0A FF	1280x720p50
		y0 50 0C FF	PAL

		y0 50 0D FF	PAL
		y0 50 0E FF	PAL
IR_Receive	8x 09 06 08 FF	y0 50 02 FF	On
		y0 50 03 FF	Off
Pan-tiltMaxSpeedInq	8x 09 06 11 FF	y0 50 ww zz FF	ww: Pan Max Speed zz: Tilt Max Speed
Pan-tiltPosInq	8x 09 06 12 FF	y0 50 0w 0w 0w 0w	www: Pan Position
		0z 0z 0z 0z FF	zzzz: Tilt Position
CAM_TypeInq	8x 09 00 03 FF	y0 50 01 FF	C Type
		y0 50 02 FF	M Type
		y0 50 03 FF	S Type
CAM_DateInq	8x 09 00 04 FF	y0 50 0r ss uu uu vv	Version dater: Big
		ww 0D FF	Version Numberss: Little Version
			Numberuuuu: Yearvv: Monthww: Day
CAM_ModelInq	8x 09 04 A6 FF	y0 50 00 FF	Mode0
		y0 50 02 FF	Mode2
CAM_GainLimitInq	8x 09 04 2C FF	y0 50 0q FF	p: Gain Limit
CAM_DHotPixelInq	8x 09 04 56 FF	y0 50 0q FF	p: Dynamic Hot Pixel Setting (0: Off, level 1 to 6)

CAM_AF SensitivityInq	8x 09 04 58 FF	y0 50 01 FF	High
		y0 50 02 FF	Normal
		y0 50 03 FF	Low
CAM_Brightness Inq	8x 09 04 A1 FF	y0 50 00 00 0p 0q FF	pq: Brightness Position
CAM_Contrast Inq	8x 09 04 A2 FF	y0 50 00 00 0p 0q FF	pq: Contrast Position
CAM_Flip Inq	8x 09 04 A4 FF	y0 50 00 FF	Off
		y0 50 01 FF	Flip-H
		y0 50 02 FF	Flip-V
		y0 50 03 FF	Flip-HV
CAM_Iridix Inq	8x 09 04 A7 FF	y0 50 00 00 0p 0q FF	pq: Iridix Position
CAM_AF Zone	8x 09 04 AA FF	y0 50 00 FF	Top
		y0 50 01 FF	Center
		y0 50 02 FF	Bottom
CAM_ColorHue Inq	8x 09 04 4F FF	y0 50 00 00 00 0p FF	p: Color Hue setting 0h (- 14 degrees) to Eh (+14 degrees)
CAM_AWB SensitivityInq	8x 09 04 A9 FF	y0 50 00 FF	High
		y0 50 01 FF	Normal
		y0 50 02 FF	Low

Command
Command Package
Return Package
Note

CAM_LensBlockInq	8x 09 7E 7E 00 FF	y0 50 0u 0u 0u 0u 00	uuuu: Zoom Position
		00 0v 0v	vvvv: Focus Position
		0v 0v 00 0w 00 FF	w.bit0: Focus Mode 1: Auto 0: Manual
CAM_CameraBlockInq	8x 09 7E 7E 01 FF	y0 50 0p 0p 0q 0q 0r	pp: R_Gain
		0s tt 0u vv ww 00 xx	qq: B_Gain
		0z FF	r: WB Mode
			s: Aperture
			tt: AE Mode
			uu: BackLight
			uu Exp Comp.
			vv: Shutter Position
			ww: Iris Position
			xx Bright Position
	z: Exp Comp. Position		
CAM_OtherBlockInq	8x 09 7E 7E 02 FF	y0 50 0p 0q 00 0r 00	p.bit0: Power 1:On,
		00 00 00	0:Off
		00 00 00 00 00 FF	q.bit2: LR Reverse 1:On, 0:Off
		r.bit3~0: Picture Effect Mode	

CAM_EnlargementBI	8x 09 7E 7E 03 FF	y0 50 00 00 00 00 00	p: AF sensitivity
ocklnq		00 00 0p	q: bit0: Picture
		0q rr 0s 0t 0u FF	flip(1:On, 0:Off)
			rr.bit6~3: Color Gain
			(0h(60%) to Eh(200%))
			s: Flip(0: Off, 1:Flip-H,
			2:Flip-V, 3:Flip-HV)
			t: bit2~0: NR2D level
			u: Gain limit

Remark:

1.[x] in the above list refer to the camera address,

[y] = [x + 8]

Pelco-D Protocol Command List

Function	Byte1	Byte2	Byte3	Byte4	Byte5	Byte6	Byte7
Up	0xFF	Address	0x00	0x08	Pan Speed	Tilt Speed	SUM
Down	0xFF	Address	0x00	0x10	Pan Speed	Tilt Speed	SUM
Left	0xFF	Address	0x00	0x04	Pan Speed	Tilt Speed	SUM
Right	0xFF	Address	0x00	0x02	Pan Speed	Tilt Speed	SUM
Zoom In	0xFF	Address	0x00	0x20	0x00	0x00	SUM
Zoom Out	0xFF	Address	0x00	0x40	0x00	0x00	SUM
Focus Far	0xFF	Address	0x00	0x80	0x00	0x00	SUM
Focus Near	0xFF	Address	0x01	0x00	0x00	0x00	SUM
Set Preset	0xFF	Address	0x00	0x03	0x00	Preset ID	SUM
Clear Preset	0xFF	Address	0x00	0x05	0x00	Preset ID	SUM
Call Preset	0xFF	Address	0x00	0x07	0x00	Preset ID	SUM
Auto Focus	0xFF	Address	0x00	0x2B	0x00	0x01	SUM
Manual Focus	0xFF	Address	0x00	0x2B	0x00	0x02	SUM
Query Pan Position	0xFF	Address	0x00	0x51	0x00	0x00	SUM
Query Pan Position	0xFF	Address	0x00	0x59	Value High	Value Low	SUM
Response					Byte	Byte	
Query Tilt Position	0xFF	Address	0x00	0x53	0x00	0x00	SUM
Query Tilt Position	0xFF	Address	0x00	0x5B	Value High	Value Low	SUM
Response					Byte	Byte	
Query Zoom Position	0xFF	Address	0x00	0x55	0x00	0x00	SUM

Query Zoom Position	0xFF	Address	0x00	0x5D	Value High	Value Low	SUM
Response					Byte	Byte	

Pelco-P Protocol Command List

Function	Byte1	Byte2	Byte3	Byte4	Byte5	Byte6	Byte7	Byte8
Up	0xA0	Address	0x00	0x08	Pan Speed	Tilt Speed	0xAF	XOR
Down	0xA0	Address	0x00	0x10	Pan Speed	Tilt Speed	0xAF	XOR
Left	0xA0	Address	0x00	0x04	Pan Speed	Tilt Speed	0xAF	XOR
Right	0xA0	Address	0x00	0x02	Pan Speed	Tilt Speed	0xAF	XOR
Zoom In	0xA0	Address	0x00	0x20	0x00	0x00	0xAF	XOR
Zoom Out	0xA0	Address	0x00	0x40	0x00	0x00	0xAF	XOR
Focus Far	0xA0	Address	0x00	0x80	0x00	0x00	0xAF	XOR
Focus Near	0xA0	Address	0x01	0x00	0x00	0x00	0xAF	XOR
Set Preset	0xA0	Address	0x00	0x03	0x00	Preset ID	0xAF	XOR
Clear Preset	0xA0	Address	0x00	0x05	0x00	Preset ID	0xAF	XOR
Call Preset	0xA0	Address	0x00	0x07	0x00	Preset ID	0xAF	XOR
Auto Focus	0xA0	Address	0x00	0x2B	0x00	0x01	0xAF	XOR
Manual Focus	0xA0	Address	0x00	0x2B	0x00	0x02	0xAF	XOR

Query Pan Position	0xA0	Address	0x00	0x51	0x00	0x00	0xAF	XOR
Query Pan Position	0xA0	Address	0x00	0x59	Value	Value Low	0xAF	XOR
Response					High Byte	Byte		
Query Tilt Position	0xA0	Address	0x00	0x53	0x00	0x00	0xAF	XOR
Query Tilt Position	0xA0	Address	0x00	0x5B	Value	Value Low	0xAF	XOR
Response					High Byte	Byte		
Query Zoom	0xA0	Address	0x00	0x55	0x00	0x00	0xAF	XOR
Position								
Query Zoom	0xA0	Address	0x00	0x5D	Value	Value Low	0xAF	XOR
Position Response					High Byte	Byte		

VISCA over IP commands

The Avonic CM6x-IP camera is implemented with a TCP server. The TCP port number is 5678 by default and can be altered in the WebGUI. Once the connection between client and server is set up, the client will be able to send PTZ commands to the server. The server then parses and executes the PTZ command.

The Avonic IP Camera has also implemented a UDP server. The UDP port number is fixed on 1259. Once the connection between client and server is set up, the client will be able to send PTZ commands to the server. The server then parses and executes the PTZ command.

The VISCA over IP command list is based on the VISCA protocol. Not all VISCA commands

are implemented.

The PTZ Command format is according to the definition of the VISCA protocol. The VISCA address of the camera is set to 1 by default and can be changed in the WebGUI. As all cameras are uniquely identified by their IP address, all VISCA addresses of the cameras that are controlled over IP do not necessarily have to be unique.

Default settings:

TCP port 5678

UDP port 1259

VISCA address 1

The commands are as follow:

1. Camera return commands

x= Camera Address

y= Socket Number

z = Camera Address + 8

All parameter values are in HEX

Return/complete Command			
Command	Function	Command Packet	Comments
ACK/Completion Messages	ACK	90 4y FF (y: Socket No.)	Return when the command is accepted.
	Completion	90 5y FF (y: Socket No.)	Return when the command has been executed.

Error command			
Command	Function	Command Packet	Comments
Error Messages	Syntax Error	90 60 02 FF	Returned when the command format is different or when a command with illegal command parameters is accepted.
	Command Buffer Full	90 60 03 FF	Indicates that two sockets are already being used(executing two commands) and the command could not be accepted when received.
	Command Canceled	90 6y 04 FF (y: Socket No.)	Returned when a command which is being executed in a socket specified by the cancel command is canceled. The completion message for the command is not returned.
	No Socket	90 6y 05 FF (y: Socket No.)	Returned when no command is executed in a socket specified by the cancel command, or when an invalid socket number is specified.
	Command Not Executable	90 6y 41 FF (y: Execution command Socket No. Inquiry command: 0)	Returned when a command cannot be executed due to current conditions. For example, when commands controlling the focus manually are received during auto focus.

2. Camera control commands

x= Camera Address

y= Socket Number

z = Camera Address + 8

All parameter values are in HEX

Command	Function	Command Packet	Comments
AddressSet	Broadcast	88 30 01 FF	Address setting
CAM_Zoom	Stop	81 01 04 07 00 FF	
	Tele(Standard speed)	81 01 04 07 02 FF	
	Wide(Standard speed)	81 01 04 07 03 FF	
	Tele(Variable speed)	81 01 04 07 2p FF	p = 0(low speed) - F(high speed)
	Wide(Variable speed)	81 01 04 07 3p FF	
	Direct	81 01 04 47 0p 0q 0r 0s FF	pqrs(0-F): Zoom Position
CAM_Focus	Stop	81 01 04 08 00 FF	
	Far(Standard speed)	81 01 04 08 02 FF	
	Near(Standard speed)	81 01 04 08 03 FF	
	Far(Variable speed)	81 01 04 08 2p FF	p = 0(low) - F(high)
	Near(Variable speed)	81 01 04 08 3p FF	
	Direct Focus Position	81 01 04 48 0p 0q 0r 0s FF	min p = 0, q = 0, r = 0, s = 0 max p = 0, q = 6, r = E, s = A
	Auto Focus	81 01 04 38 02 FF	AF On/Off
	Manual Focus	81 01 04 38 03 FF	
CAM_WB	Auto	81 01 04 35 00 FF	Normal Auto
	Indoor mode	81 01 04 35 01 FF	Indoor mode
	Outdoor mode	81 01 04 35 02 FF	Outdoor mode
	OnePush mode	81 01 04 35 03 FF	One Push WB mode
	Manual	81 01 04 35 05 FF	Manual Control mode
	OnePush trigger	81 01 04 10 05 FF	One Push WB Trigger
CAM_RGain	Reset	81 01 04 03 00 FF	Manual Control of R Gain
	Up	81 01 04 03 02 FF	
	Down	81 01 04 03 03 FF	
	Direct	81 01 04 43 00 00 0p 0q FF	pq: R Gain
CAM_Bgain	Reset	81 01 04 04 00 FF	Manual Control of B Gain
	Up	81 01 04 04 02 FF	
	Down	81 01 04 04 03 FF	
	Direct	81 01 04 44 00 00 0p 0q FF	pq: B Gain
CAM_AE	Full Auto	81 01 04 39 00 FF	Automatic Exposure mode
	Manual	81 01 04 39 03 FF	Manual Control mode
	Shutter priority	81 01 04 39 0A FF	Shutter Priority Automatic Exposure mode
	Iris priority	81 01 04 39 0B FF	Iris Priority Automatic Exposure mode
	Bright	81 01 04 39 0D FF	Bright Mode(Manual control)
CAM_Iris	Reset	81 01 04 0B 00 FF	Iris Setting (CAM_AE is set to Iris
	Up	81 01 04 0B 02 FF	Priority)
	Down	81 01 04 0B 03 FF	

	Direct Iris Position	81 01 04 4B 00 00 0p 0q FF	min p = 0 q = 0 max p = 0, q = C
CAM_Gain	Reset	81 01 04 0C 00 FF	Gain Setting
	Up	81 01 04 0C 02 FF	
	Down	81 01 04 0C 03 FF	
	Direct	81 01 04 0C 00 00 0p 0q FF	pq: Gain Position
	Gain Limit	81 01 04 2C 0p FF	p: Gain Position
CAM_Bright	Reset	81 01 04 0D 00 FF	Bright Setting
	Up	81 01 04 0D 02 FF	
	Down	81 01 04 0D 03 FF	
	Direct	81 01 04 0D 00 00 0p 0q FF	pq: Bright Position
CAM_ExpComp	On	81 01 04 3E 02 FF	Exposure Compensation On/Off
	Off	81 01 04 3E 03 FF	
	Reset	81 01 04 0E 00 FF	Exposure Compensation Amount
	Up	81 01 04 0E 02 FF	Setting
	Down	81 01 04 0E 03 FF	
	Direct	81 01 04 4E 00 00 0p 0q FF	pq: ExpComp Position
CAM_BackLight	On	81 01 04 33 02 FF	Back Light Compensation On/Off
	Off	81 01 04 33 03 FF	
CAM_NR(2D)Mode	Auto	81 01 04 50 02 FF	ND2D Auto/Manual
	Manual	81 01 04 50 03 FF	
CAM_NR(2D)Level	-	81 01 04 53 0p FF	p: NR Setting (0: Off, level 1 to 5)
CAM_NR(3D)Level	-	81 01 04 54 0p FF	p: NR Setting (0: Off, level 1 to 8)
CAM_Flicker	-	81 01 04 23 0p FF	p: Flicker Settings (0: Off, 1: 50Hz, 2: 60Hz)
CAM_DHotPixel	-	81 01 04 56 0p FF	p: Dynamic Hot Pixel Setting (0: Off, level 1 to 6)
CAM_ApertureMode(sharpness)	Auto	81 01 04 05 02 FF	Sharpness Auto
	Manual	81 01 04 05 02 FF	Sharpness Manual
CAM_Aperture(sharpness)	Reset	81 01 04 02 00 FF	Aperture Control
	Up	81 01 04 02 02 FF	
	Down	81 01 04 02 03 FF	
	Direct	81 01 04 42 00 00 0p 0q FF	pq: Aperture Gain
CAM_PictureEffect	Off	81 01 04 63 00 FF	Picture Effect Setting
	B&W	81 01 04 63 04 FF	
CAM_Memory	Reset	81 01 04 3F 00 pp FF	pp: Memory Number(=0 to 127)
	Set	81 01 04 3F 01 pp FF	
	Recall	81 01 04 3F 02 pp FF	
CAM_LR_Reverse	On	81 01 04 61 02 FF	Image Flip Horizontal On/Off
	Off	81 01 04 61 03 FF	
CAM_PictureFlip	On	81 01 04 66 02 FF	Image Flip Vertical On/Off
	Off	81 01 04 66 03 FF	

CAM_ColorGain	Direct	81 01 04 49 00 00 00 0p FF	p: Color Gain setting 0h (60%) to Eh (200%)
SYS_Menu	Off	81 01 06 06 03 FF	Turns on/off the menu screen
	On	81 01 06 06 02 FF	
Pan_tiltDrive	Up	81 01 06 01 VV WW 03 01 FF	VV: Pan speed 0x01 (low speed) to 0x18 (high speed)
	Down	81 01 06 01 VV WW 03 02 FF	WW: Tilt speed 0x01 (low speed) to 0x14 (high speed)
	Left	81 01 06 01 VV WW 01 03 FF	YYYY: Pan Position ZZZZ: Tilt Position
	Right	81 01 06 01 VV WW 02 03 FF	
	Upleft	81 01 06 01 VV WW 01 01 FF	
	Upright	81 01 06 01 VV WW 02 01 FF	
	DownLeft	81 01 06 01 VV WW 01 02 FF	
	DownRight	81 01 06 01 VV WW 02 02 FF	
	Stop	81 01 06 01 VV WW 03 03 FF	
	AbsolutePosition	81 01 06 02 VV WW 0Y 0Y 0Y 0Y 0Z 0Z 0Z 0Z FF	
	RelativePosition	81 01 06 03 VV WW 0Y 0Y 0Y 0Y 0Z 0Z 0Z 0Z FF	
	Home	81 01 06 04 FF	
	Reset	81 01 06 05 FF	
	Pan_tiltLimitSet	LimitSet	81 01 06 07 00 0W 0Y 0Y 0Y 0Y 0Z 0Z 0Z 0Z FF
LimitClear		81 01 06 07 01 0W 07 0F 0F 0F 07 0F 0F 0F FF	ZZZZ: Tilt Position
CAM_AFSensitivity	High	81 01 04 58 01 FF	AF Sensitivity High/Normal/Low
	Normal	81 01 04 58 02 FF	
	Low	81 01 04 58 03 FF	
CAM_SettingReset	Reset	81 01 04 A0 10 FF	Reset Factory Setting
CAM_Brightness	Direct	81 01 04 A1 00 00 0p 0q FF	pq: Brightness Position
CAM_Contrast	Direct	81 01 04 A2 00 00 0p 0q FF	pq: Contrast Position
CAM_Flip	Off	81 01 04 A4 00 FF	Single Command For Video Flip
	Flip-H	81 01 04 A4 01 FF	
	Flip-V	81 01 04 A4 02 FF	
	Flip-HV	81 01 04 A4 03 FF	
CAM_SettingSave	Save	81 01 04 A5 10 FF	Save Current Setting

CAM_Iridix	Direct	81 01 04 A7 00 00 0p 0q FF	pq: Iridix Position
CAM_AWBSensitivity	High	81 01 04 A9 00 FF	High
	Normal	81 01 04 A9 01 FF	Normal
	Low	81 01 04 A9 02 FF	Low
CAM_AFZone	Top	81 01 04 AA 00 FF	AF Zone weight select
	Center	81 01 04 AA 01 FF	
	Bottom	81 01 04 AA 02 FF	
CAM_ColorHue	Direct	81 01 04 4F 00 00 00 0p FF	p: Color Hue setting 0h (- 14 degrees) to Eh (+14 degrees)

3. Inquiry Commands

x= Camera Address

y= Socket Number

z = Camera Address + 8

All parameter values are in HEX

Inquiry Command			
Command	Command Packet	Packet	Comments
CAM_ZoomPosInq	81 09 04 47 FF	90 50 0p 0q 0r 0s FF	pqrs: Zoom Position
CAM_FocusAFMod elinq	81 09 04 38 FF	90 50 02 FF	Auto Focus
		90 50 03 FF	Manual Focus
CAM_FocusPosInq	81 09 04 48 FF	90 50 0p 0q 0r 0s FF	pqrs: Focus Position
CAM_WBModelInq	81 09 04 35 FF	90 50 00 FF	Auto
		90 50 01 FF	Indoor mode
		90 50 02 FF	Outdoor mode
		90 50 03 FF	OnePush mode
		90 50 05 FF	Manual
CAM_RGainInq	81 09 04 43 FF	90 50 00 00 0p 0q FF	pq: R Gain
CAM_BGainInq	81 09 04 44 FF	90 50 00 00 0p 0q FF	pq: B Gain
CAM_AEModelInq	81 09 04 39 FF	90 50 00 FF	Full Auto
		90 50 03 FF	Manual
		90 50 0A FF	Shutter priority
		90 50 0B FF	Iris priority
		90 50 0D FF	Bright
CAM_ShutterPosIn	81 09 04 4A FF	90 50 00 00 0p 0q FF	pq: Shutter Position

q			
CAM_IrisPosInq	81 09 04 4B FF	90 50 00 00 0p 0q FF	pq: Iris Position
CAM_BrightPosInq	81 09 04 4D FF	90 50 00 00 0p 0q FF	pq: Bright Position
CAM_ExpCompMo	81 09 04 3E FF	90 50 02 FF	On
delnq		90 50 03 FF	Off
CAM_ExpCompPo	81 09 04 4E FF	90 50 00 00 0p 0q FF	pq: ExpComp Position
slnq			
CAM_BacklightMo	81 09 04 33 FF	90 50 02 FF	On
delnq		90 50 03 FF	Off
CAM_Nosise2DMo	81 09 04 50 FF	90 50 02 FF	Auto Noise 2D
delng		90 50 03 FF	Manual Noise 3D
CAM_Nosise2DLev	81 09 04 53 FF	90 50 0p FF	Noise Reduction (2D) p: 0 to 5
el			
CAM_Noise3DLeve	81 09 04 54 FF	90 50 0p FF	Noise Reduction (3D) p: 0 to 8
l			
CAM_FlickerModel	81 09 04 55 FF	90 50 0p FF	p: Flicker Settings(0: OFF, 1: 50Hz, 2: 60Hz)
nq			
CAM_ApertureMod	81 09 04 05 FF	90 50 02 FF	Auto Sharpness
elnq(Sharpness)		90 50 03 FF	Manual Sharpness
CAM_ApertureInq(Sharpness)	81 09 04 42 FF	90 50 00 00 0p 0q FF	pq: Aperture Gain
CAM_PictureEffect	81 09 04 63 FF	90 50 02 FF	Off
Modelnq		90 50 04 FF	B&W
CAM_MemoryInq	81 09 04 3F FF	90 50 0p FF	p: Memory number last operated.
SYS_MenuModeln	81 09 06 06 FF	90 50 02 FF	On
q		90 50 03 FF	Off
CAM_LR_Reversel	81 09 04 61 FF	90 50 02 FF	On
nq		90 50 03 FF	Off
CAM_PictureFlipIn	81 09 04 66 FF	90 50 02 FF	On
q		90 50 03 FF	Off
CAM_ColorGainInq	81 09 04 49 FF	90 50 00 00 00 0p FF	p: Color Gain setting 0h (60%) to Eh (200%)
VideoSystemInq	81 09 06 23 FF	90 50 00 FF	1920x1080i60
		90 50 01 FF	1920x1080p30
		90 50 02 FF	1280x720p60
		90 50 04 FF	NTSC
		90 50 05 FF	NTSC
		90 50 06 FF	NTSC
		90 50 07 FF	1920x1080p60
		90 50 08 FF	1920x1080i50
		90 50 09 FF	1920x1080p25
		90 50 0A FF	1280x720p50

		90 50 0C FF	PAL
		90 50 0D FF	PAL
		90 50 0E FF	PAL
Pan-tiltMaxSpeedInq	81 09 06 11 FF	90 50 ww zz FF	ww: Pan Max Speed zz: Tilt Max Speed
Pan-tiltPosInq	81 09 06 12 FF	90 50 0w 0w 0w 0w 0z 0z 0z 0z FF	www: Pan Position zzzz: Tilt Position
CAM_GainLimitInq	81 09 04 2C FF	90 50 0q FF	p: Gain Limit
CAM_DHotPixelInq	81 09 04 56 FF	90 50 0q FF	p: Dynamic Hot Pixel Setting (0: Off, level 1 to 6)
CAM_AFSensitivityInq	81 09 04 58 FF	90 50 01 FF	High
		90 50 02 FF	Normal
		90 50 03 FF	Low
CAM_BrightnessInq	81 09 04 A1 FF	90 50 00 00 0p 0q FF	pq: Brightness Position
CAM_ContrastInq	81 09 04 A2 FF	90 50 00 00 0p 0q FF	pq: Contrast Position
CAM_FlipInq	81 09 04 A4 FF	90 50 00 FF	Off
		90 50 01 FF	Flip-H
		90 50 02 FF	Flip-V
		90 50 03 FF	Flip-HV
CAM_IridixInq	81 09 04 A7 FF	90 50 00 00 0p 0q FF	pq: Iridix Position
CAM_AFZone	81 09 04 AA FF	90 50 00 FF	Top
		90 50 01 FF	Center
		90 50 02 FF	Bottom
CAM_ColorHueInq	81 09 04 4F FF	90 50 00 00 00 0p FF	p: Color Hue setting 0h (- 14 degrees) to Eh (+14 degrees)
CAM_AWBSensitivityInq	81 09 04 A9 FF	90 50 00 FF	High
		90 50 01 FF	Normal
		90 50 02 FF	Low

Appendix B Quick Start

Step1. Please check connections are correct before starting

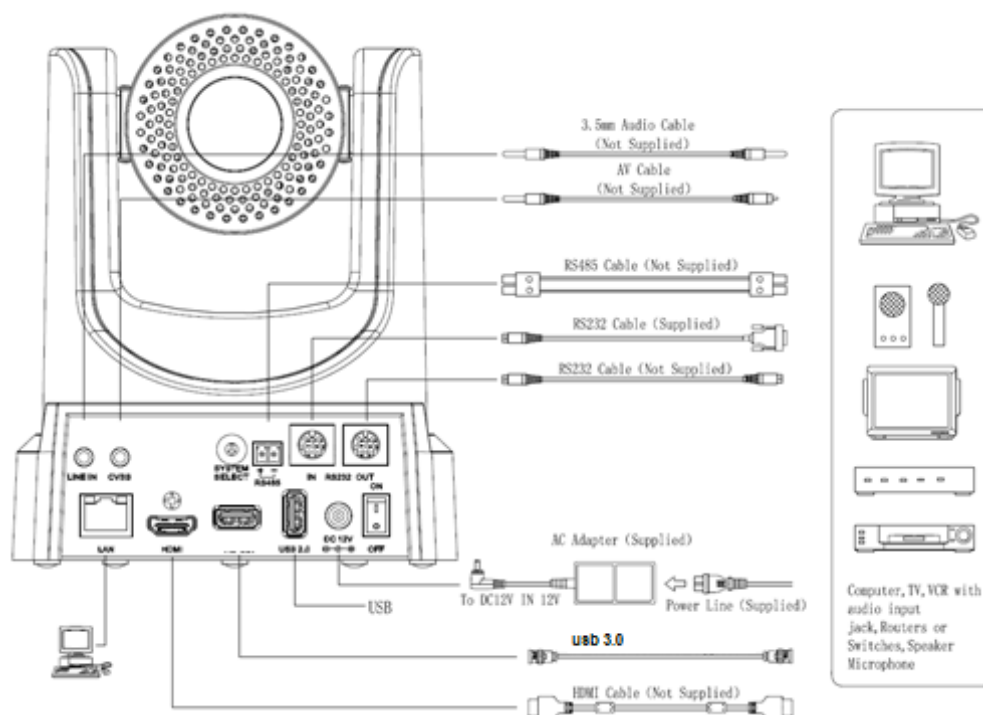

Step2. Select desired resolution output on the System Selector on the back of the camera.

Use a flat screw driver.

Step3. Press the Switch ON/OFF button on the rear of the camera, the power lamp light.

Step4. Pan-Tilt will rotate to the maximum position of top right after the camera started, then it return to the center, the process of initialization is finished. (Note: If the position preset 0 has been stored, the position preset 0 will be called up after initialization)

Appendix C Dimensions

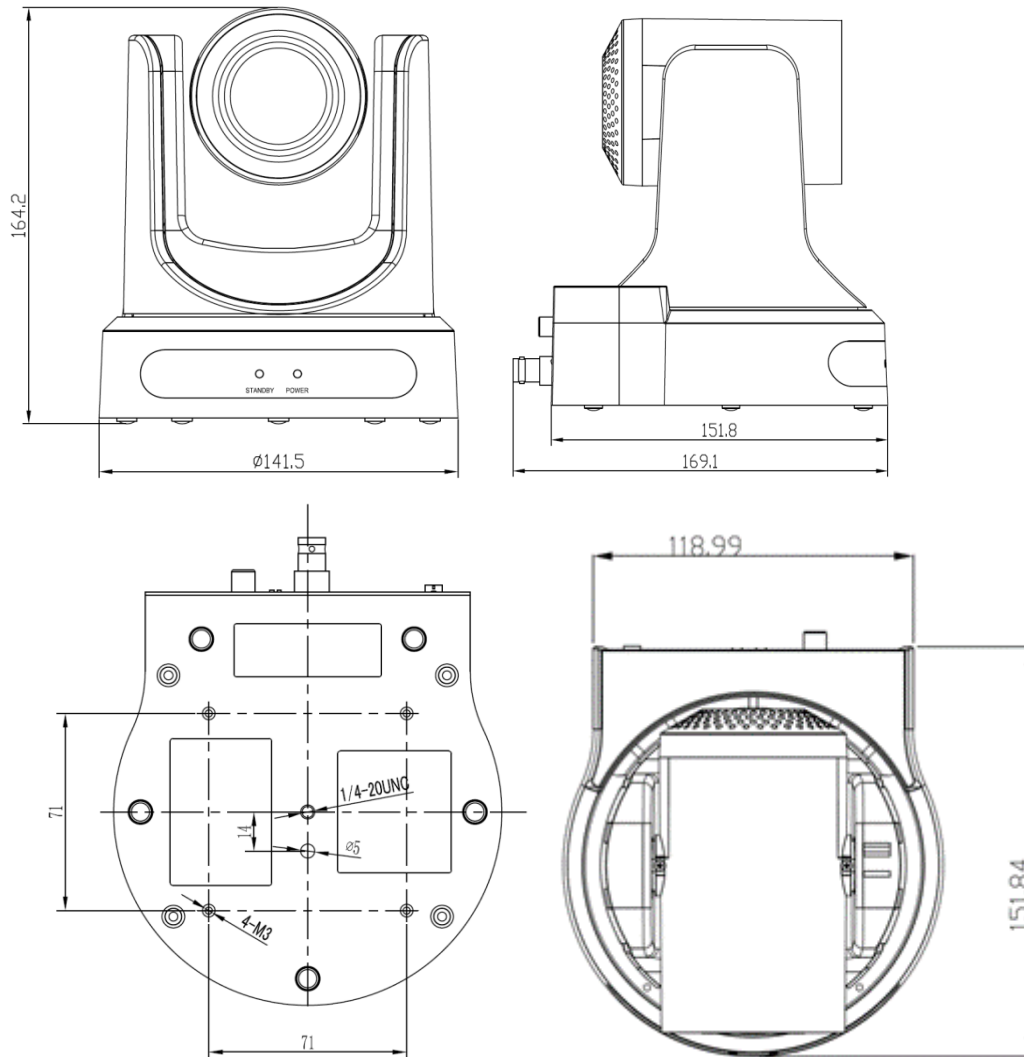

All sizes are in mm

Weight: 2.4 kg