

XR624 & XR824

Professional Studio Monitors

OWNER'S MANUAL



Important Safety Instructions

1. Read these instructions.
2. Keep these instructions.
3. Heed all warnings.
4. Follow all instructions.
5. Do not use this apparatus near water.
6. Clean only with a dry cloth.
7. Do not block any ventilation openings. Install in accordance with the manufacturer's instructions.
8. Do not install near any heat sources such as radiators, heat registers, stoves, or other apparatus (including amplifiers) that produce heat.
9. Do not defeat the safety purpose of the polarized or grounding-type plug. A polarized plug has two blades with one wider than the other. A grounding-type plug has two blades and a third grounding prong. The wide blade or the third prong are provided for your safety. If the provided plug does not fit into your outlet, consult an electrician for replacement of the obsolete outlet.
10. Protect the power cord from being walked on or pinched particularly at plugs, convenience receptacles, and the point where they exit from the apparatus.
11. Only use attachments/accessories specified by the manufacturer.
12. Use only with a cart, stand, tripod, bracket, or table specified by the manufacturer, or sold with the apparatus. When a cart is used, use caution when moving the cart/apparatus combination to avoid injury from tip-over.
13. Unplug this apparatus during lightning storms or when unused for long periods of time.
14. Refer all servicing to qualified service personnel. Servicing is required when the apparatus has been damaged in any way, such as power-supply cord or plug is damaged, liquid has been spilled or objects have fallen into the apparatus, the apparatus has been exposed to rain or moisture, does not operate normally, or has been dropped.
15. This apparatus shall not be exposed to dripping or splashing, and no object filled with liquids, such as vases or beer glasses, shall be placed on the apparatus.
16. Do not overload wall outlets and extension cords as this can result in a risk of fire or electric shock.
17. This apparatus has been designed with Class-I construction and must be connected to a mains socket outlet with a protective earthing connection (the third grounding prong).
18. This apparatus has been equipped with a rocker-style AC mains power switch. This switch is located on the rear panel and should remain readily accessible to the user.
19. The MAINS plug or an appliance coupler is used as the disconnect device, so the disconnect device shall remain readily operable.



CAUTION

RISK OF ELECTRIC SHOCK! DO NOT OPEN!

CAUTION: TO REDUCE THE RISK OF ELECTRIC SHOCK DO NOT REMOVE COVER (OR BACK). NO USER-SERVICEABLE PARTS INSIDE. REFER SERVICING TO QUALIFIED PERSONNEL.



The lightning flash with arrowhead symbol within an equilateral triangle is intended to alert the user to the presence of uninsulated "dangerous voltage" within the product's enclosure, that may be of significant magnitude to constitute a risk of electric shock to persons.



The exclamation point within an equilateral triangle is intended to alert the user of the presence of important operating and maintaining (servicing) instructions in the literature accompanying the appliance.

20. NOTE: This equipment has been tested and found to comply with the limits for a Class B digital device, pursuant to part 15 of the FCC Rules. These limits are designed to provide reasonable protection against harmful interference in a residential installation. This equipment generates, uses, and can radiate radio frequency energy and, if not installed and used in accordance with the instructions, may cause harmful interference to radio communications. However, there is no guarantee that interference will not occur in a particular installation. If this equipment does cause harmful interference to radio or television reception, which can be determined by turning the equipment off and on, the user is encouraged to try to correct the interference by one or more of the following measures:

- Reorient or relocate the receiving antenna.
- Increase the separation between the equipment and the receiver.
- Connect the equipment into an outlet on a circuit different from that to which the receiver is connected.
- Consult the dealer or an experienced radio/TV technician for help.

CAUTION: Changes or modifications to this device not expressly approved by LOUD Technologies Inc. could void the user's authority to operate the equipment under FCC rules.

21. This apparatus does not exceed the Class A/Class B (whichever is applicable) limits for radio noise emissions from digital apparatus as set out in the radio interference regulations of the Canadian Department of Communications.

ATTENTION — *Le présent appareil numérique n'émet pas de bruits radioélectriques dépassant les limites applicables aux appareils numériques de class A/de class B (selon le cas) prescrites dans le règlement sur le brouillage radioélectrique édicté par les ministères des communications du Canada.*

22. Exposure to extremely high noise levels may cause permanent hearing loss. Individuals vary considerably in susceptibility to noise-induced hearing loss, but nearly everyone will lose some hearing if exposed to sufficiently intense noise for a period of time. The U.S. Government's Occupational Safety and Health Administration (OSHA) has specified the permissible noise level exposures shown in the following chart.

According to OSHA, any exposure in excess of these permissible limits could result in some hearing loss. To ensure against potentially dangerous exposure to high sound pressure levels, it is recommended that all persons exposed to equipment capable of producing high sound pressure levels use hearing protectors while the equipment is in operation. Ear plugs or protectors in the ear canals or over the ears must be worn when operating the equipment in order to prevent permanent hearing loss if exposure is in excess of the limits set forth here:

Duration, per day in hours	Sound Level dBA, Slow Response	Typical Example
8	90	Duo in small club
6	92	
4	95	Subway Train
3	97	
2	100	Very loud classical music
1.5	102	
1	105	Jon screaming at Karl about deadlines
0.5	110	
0.25 or less	115	Loudest parts at a rock concert

WARNING — To reduce the risk of fire or electric shock, do not expose this apparatus to rain or moisture.

Laite on liitettävä suojakoskettimilla varustettuun pistorasiaan.

Apparatet må tilkoples jordnet stikkontakt.

Apparaten skall anslutas till jordat uttag.

Contents

- IMPORTANT SAFETY INSTRUCTIONS**2
- INTRODUCTION**4
 - QUICK START**.....5
 - HOOKUP DIAGRAMS**.....6
- REAR PANEL DESCRIPTION**7
 - 1. POWER CONNECTOR**7
 - 2. POWER SWITCH**7
 - 3. AC SELECT SWITCH**.....7
 - 4. SIGNAL INPUTS**.....7
 - 5. INPUT SENSITIVITY**8
 - 6. ACOUSTIC SPACE**.....8
 - 7. LOW FREQUENCY FILTER**.....8
 - 8. HIGH FREQUENCY FILTER**8
 - 9. POWER MODE**9
 - 10. CUSTOM-TUNED REAR PORT**9
- FRONT PANEL DESCRIPTION**.....9
 - 11. POWER/OVERLOAD LED**9
- PROTECTION CIRCUITS**10
 - OVEREXCURSION PROTECTION**10
 - THERMAL PROTECTION**.....10
 - INTEGRATED MAGNETIC SHIELDING**.....10
 - OVERLOAD PROTECTION**10
 - INPUT SIGNAL WIRING**.....10
- CARE AND CLEANING**10
- APPENDIX A: SERVICE INFO**11
 - TROUBLESHOOTING**.....11
 - REPAIR**.....12
- APPENDIX B: TECHNICAL INFORMATION**13
 - XR SERIES SPECIFICATIONS**13
 - XR SERIES DIMENSIONS**.....14
- XR SERIES LIMITED WARRANTY**15

Please write your serial number here for future reference (i.e., insurance claims, tech support, return authorization, make dad proud, etc.)

Purchased at:

Date of purchase:

XR Series Features

- Professional level performance
 - Logarithmic waveguide provides acoustic alignment for balanced sound across the entire frequency spectrum
 - ELP™ Bass Reflex System engineered for zero turbulence, providing greatly increased output capability and extended low-frequency response
 - 1" black anodized aluminum tweeter reveals the finest details and upper harmonics of your mix.
 - 6.5" (XR624) or 8" (XR824) Kevlar® woofer offers fast transient recovery for incredibly accurate low frequency response
 - 160W bi-amplified Class-D amplification (100LF / 60HF)
 - Frequency response: 45Hz – 22kHz (XR624) or 36Hz – 22kHz (XR824)
- Optimize XR monitors for your sound and mixing environment
 - Adjustable acoustic space filters maintain flat response in typical placement
 - HF filter applies boost or cut to compensate for particularly dull or bright sounding rooms
 - LF filter rolls off the low end to simulate smaller speakers for reference
- Attention to the detail
 - Eco-friendly auto turn-off / turn-on
 - Black wood grain finish for a classic studio feel
 - Specially designed internal bracing adds stiffness for reduced distortion and enhanced clarity
 - Included custom acoustic isolation pad reduces unwanted resonance and improves bass response



Like us



Follow us



Watch our dang videos

Introduction

You are passionate about your music, your projects and your mix. XR Series monitors are designed to bring you closer to your mix than ever before.

The result of countless hours of tuning and development, XR monitors utilize premium components with superior acoustic and amplifier design for incredible accuracy and clarity. We know you will spend many long nights with these, so we specifically designed them to translate your mix in a way that feels natural without the ear fatigue caused by harsh mids and highs in other monitors.

Hearing every detail makes all the difference. The logarithmic waveguide matches the high frequency dispersion pattern to that of the woofer for a seamless midrange transition. It also recesses the tweeter so that its active area is on the same axis with the woofer, providing acoustic alignment of high and low frequencies for the perfect balance between articulate highs and midrange clarity. This precise waveguide design provides a level sensitivity that reveals things you didn't know were in your mix before.

XR monitors are engineered for serious professional level performance. For the most accurate and clean low end possible, XR series monitors are equipped with a Kevlar® woofer which provides fast recovery from transients making muddy low-end a thing of the past by virtually eliminating resonant frequencies produced by typical woofer types. Plus, the custom designed ELP™ (Extended Length Port) Bass Reflex System provides enhanced low frequency response and increased output capability that enables you to hear all the warm low end in every mix. This is achieved by an extended length, internally curved design and a flush-mount, zero-turbulence exit. High frequencies require precision and the 1" black anodized aluminum tweeter delivers clear, shimmering highs that reveal every detail of your mix with unmatched accuracy. And with their class-leading 160W of power, XR monitors deliver clean, distortion-free performance at the high output levels required by modern studios.

No two rooms are the same. XR monitors are easily adaptable to suit your mixing environment to ensure a flat frequency response with carefully tuned acoustic space filters. Whole space, Half Space and Quarter Space filters allow you to maintain a flat frequency response for the most common speaker placement configurations. Also included are low and high frequency filters to further customize your listening experience.

Attention to detail makes all the difference when it comes to true professional studio monitors, and we didn't compromise on any. Rather than a simple bolt-on rear port, we created a unique mount that allows it to sit perfectly flush with the chassis which not only looks better, but contributes to enhanced acoustic performance. The eco-friendly Auto On/Off puts the monitor in stand-by after a period of time with no signal and back on as soon as signal is present. And the bi-color front-panel LED, set to the perfect non-intrusive brightness level, provides visual feedback keeping you informed on the monitor's status. Adding the finishing touches are the robust metal toggle switches that offer excellent durability and the classic wood-grain finish that looks great in any studio.

It's time to reveal your true mix - Mackie XR™ Series Professional Studio Monitors.

A Variety Of Applications...

XR Series Professional Studio Monitors may be used in a variety of applications. Some examples include:

- Home and project studios – Music production for solo artists, small bands and DJs.
- Commercial Music Studios – Post-production edit/mix suites, recording, editing, mixdown, mastering of everything from spoken word performances to full music productions.
- A/V broadcast studios – Live broadcast/streaming of audio-only or AV content such as radio and TV. Production/Post-production focused on podcasts or other streaming audio. Voiceovers, too.
- Video post-production – Edit suites for small productions such as commercials, budget films or multimedia for internet broadcast, etc.
- Home theater and other multimedia – Music and movie playback, video game sound system, social function/party system, etc.

Quick Start

We realize that you can't wait to hook up your XR Series Studio Monitors and try them out. Nevertheless, please take the time to read this page NOW, and the rest can wait until you're good and ready.

There are a number of other settings you can make on the back of the XR Series, but for now, just leave them at the factory default settings.

1. Turn the Input Sensitivity Level [5] control on the back of the cabinet down (fully counterclockwise) before turning on the monitor for the first time.
2. Set the power switch [2] on the back panel off. This will prevent you from accidentally connecting a hot signal source to the monitor and getting a rude surprise.
3. Leave the low freq [7] and high freq [8] filter switches at their normal positions.
4. Connect the line-level monitor signal from your mixer, preamp, or other signal source to the 1/4" or XLR input jack [4] on the XR Series Studio Monitor.
5. Connect the supplied AC power cord to the (1) IEC socket on the back of the monitor. Plug the other end into an AC outlet properly configured with the voltage corresponding to the markings next to the IEC socket.
6. Start your signal source (8-track player, turntable, CD player, DAW, or whatever), but leave the master volume control on the mixer or preamp down.
7. Turn on the power switch [2] on the XR Series monitor. The LED on the front panel will illuminate.
8. Slowly turn up the Input Sensitivity Level [5] control on the back of the monitor to the Normal position (MAX).
9. Adjust the master volume on the mixer or preamp to a comfortably loud listening level. If the XR monitor gets loud really fast, turn down the Input Sensitivity Level control to its center position (12 o'clock) to provide more volume control on the mixer or preamp.

An Extremely Important Note on XR Series Bass Response and Your Control Room

Your new XR Series monitors achieve their best bass response in a room that's optimized for bass reproduction. A lot of factors can conspire to thwart the XR's extended low frequency — including room shape, room volume and acoustical treatment. This is not a cop-out or an apology. It's plain old physics in action. Luckily we've armed you with some compensating controls that you can use to optimize the frequency response of the speakers in your particular room. Consider the following:

Low-Frequency Response



When you put your XR series monitors in a corner or up against walls, their bass characteristics change. The apparent loudness of the low frequencies increases when the monitors are placed close to a wall, and even more so when they are placed in a corner. The Acoustic Space [6] switch must be set correctly. Adjust the Acoustic Space switch setting accordingly to avoid muddy or exaggerated low frequency response.

High-Frequency Response

XR series monitors are designed to provide a smooth frequency response throughout the mid and high range. Nevertheless, you may decide that you need a little more or a little less high frequencies in your monitors while you are mixing. The high freq filter [8] switch provides a gentle boost or cut to the tweeter. Remember that boosting the high frequencies in the monitors can result in a duller mix, while reducing the high frequencies can result in a brighter overall mix.

Additional Tidbits of Wisdom

- Never listen to loud music for prolonged periods. Please see the Safety Instructions on page 2 for information on hearing protection.
- When you shut down your equipment, turn off the XR Series studio monitors first to prevent thumps and other noises generated by any upstream equipment from coming out the speakers. When powering up, turn on the monitors last.
- Save the shipping box! You may need it someday.
- Save your sales receipt in a safe place. It's your warranty!

Placement

XR Series monitors were designed to be placed in a vertical position. If you find it necessary to place the speakers in a horizontal position (on their sides), place them so that the woofers are toward the inside; that is, so the woofers are closest to each other. This provides the best low-frequency summing and overall imaging.

When the monitor is operated at high sound pressure levels, a fair bit of heat can be generated by the internal power amplifiers. These internal amplifiers are part of the rear panel electronics assembly. To ensure adequate ventilation, the rear of the monitor should be placed at least three inches away from the wall.

Hookup Diagrams

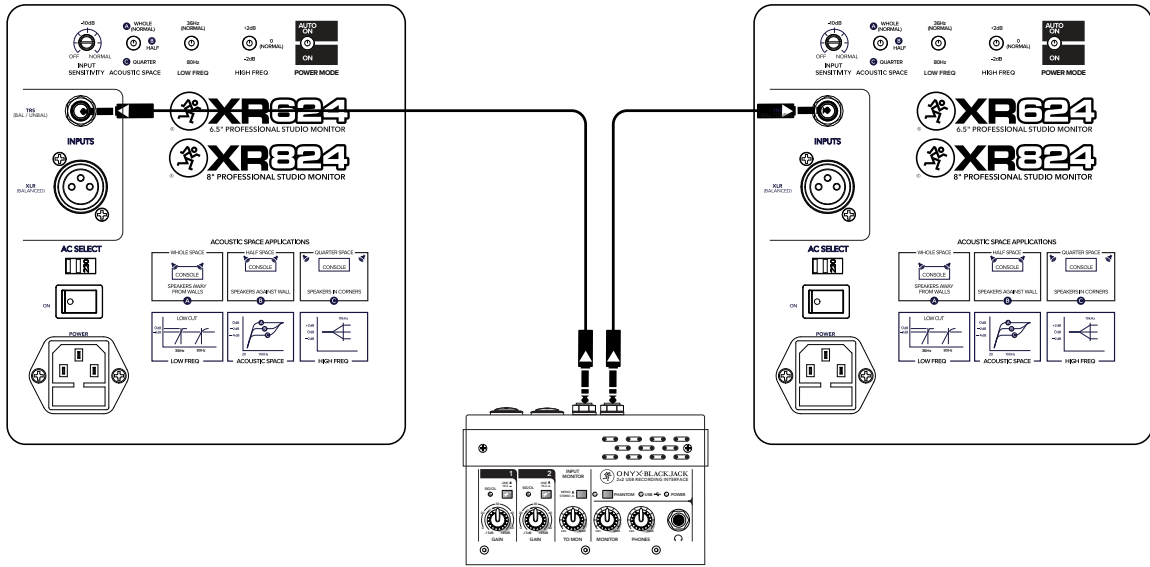

In this example, an Onyx Blackjack interface is connected directly to two XR Series monitors.

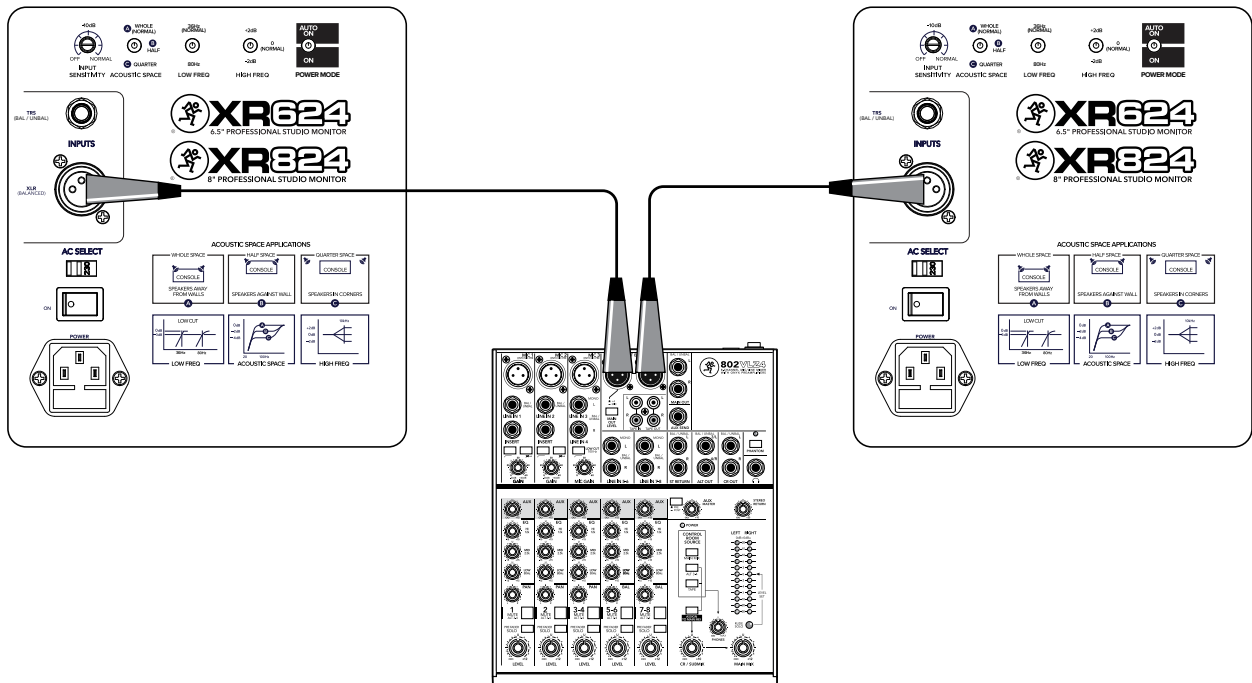

In this example, an 802VLZ4 mixer is connected directly to two XR Series monitors.

Rear Panel Description

This is where you connect your signal to the monitor, and make adjustments to the frequency response of the speakers to match the monitor's location and your room's environment.

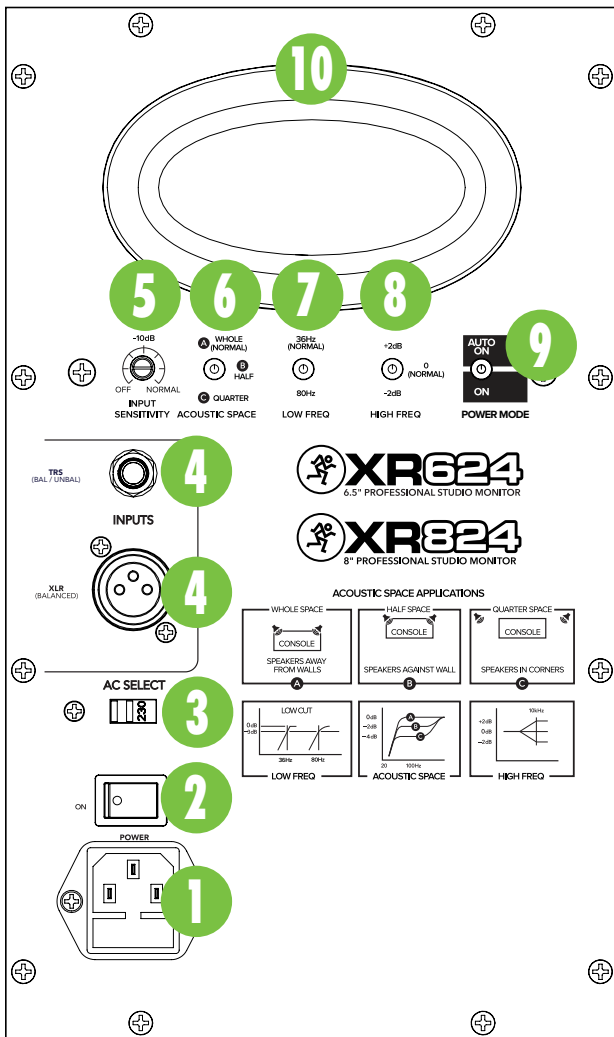

1. Power Connector

This is a standard 3-prong IEC power connector. Connect the detachable linecord (included in the box) to the power receptacle, and plug the other end of the linecord into an AC outlet.

WARNING: Before plugging the AC power cord into your XR monitor, make sure that the voltage selector [3] slide switch is set to the same voltage as the local AC mains supply. Only slide the voltage switch with the power cord unplugged using a flat headed screwdriver.

WARNING: Disconnecting the plug's ground pin is dangerous. Don't do it.

FUSE: Each XR monitor is fused for your (and its own) protection. If you suspect a blown fuse, disconnect the AC mains power cord, pull the fuse drawer out (located just below the cord receptacle) and replace fuse with a T2.5AL/250V replacement, available at electronics stores or your dealer. Use a T1.25AL/250V fuse if the local voltage is 220-240 VAC.

2. Power Switch

Use this switch to turn XR series monitors on or off. It works with the Power Mode [9] switch on the rear panel in the following way:

- If the Power Mode switch is ON, the rear panel power switch turns the XR monitor on.
- If the Power Mode switch is in the Auto On position, the front panel power switch turns the XR monitor on, even when there is no signal present. If there is no signal after about fifteen minutes, the auto-off function is activated and the amplifiers go into Standby mode, indicated when the front LED goes off.

3. AC Select Switch

Switches the unit between 100-120V and 220-240V power for worldwide use.

4. Signal Inputs

Connect the line-level signal from the mixer (or other signal source) to one of these input jacks. There are two types of input connectors to choose from: XLR and 1/4-inch.

- The XLR female and TRS female input connectors are provided for user convenience.
- Don't connect more than one source to the jacks.
- Unbalanced TS (tip-sleeve) lines can be accommodated via the TRS jack. Make sure the cable terminates with a TS plug (like a guitar plug), or if it's a TRS plug (such as a headphone plug), make sure the ring is tied to the sleeve and that the plug is fully inserted into the jack.
- The XLR and TRS input connectors accept balanced or unbalanced signals. The connectors are wired as follows (per the AES/IEC standard):

Balanced XLR

Hot (+)	Pin 2
Cold (-)	Pin 3
Shield (Ground)	Pin 1

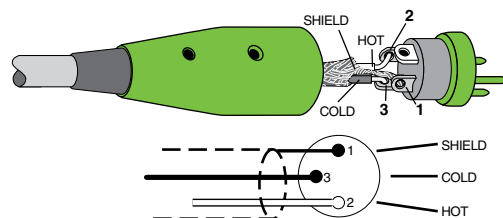

Balanced XLR Connectors

Balanced 1/4" TRS

Hot (+)	Tip
Cold (-)	Ring
Shield (Ground)	Sleeve

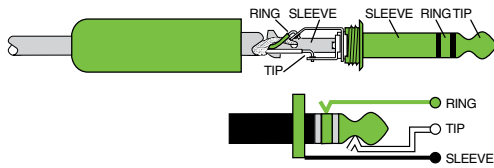
**Balanced 1/4" Connectors****Unbalanced 1/4" TS**

Hot (+)	Tip
Cold (-)	Ring
Shield (Ground)	Sleeve

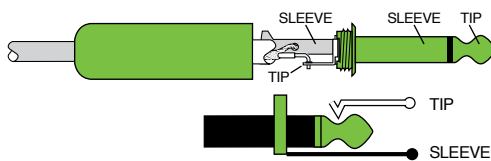
**Unbalanced 1/4" Connectors****5. Input Sensitivity**

The XR series expects a line-level signal at its input connectors.

- XR series monitors are designed to operate with a +4 dBu signal when the Input Sensitivity control is in the Normal position.
- Refer to the Quick Start section on page 5 for the level-setting procedure.

6. Acoustic Space

This is a three-way toggle switch that adjusts the low-frequency response of the monitors to compensate for their placement in the room.

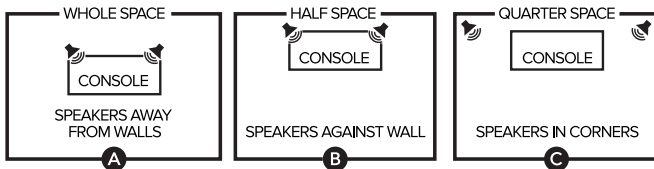
ACOUSTIC SPACE APPLICATIONS

- If you use the XR Series monitors free-standing, away from walls and corners (whole space), set the Acoustic Space switch to the whole position (Normal).
- If you place the XR Series monitors against a wall (half space), set the Acoustic Space switch to the half position. This activates a shelving filter to reduce the low-frequency output by 2 dB to compensate for the half-space placement.

- If you place the monitors into the corners of your room (quarter space), the low-frequency output approximately doubles from what it is in half space. Set the Acoustic Space switch to the quarter position to reduce the low-frequency output by 4 dB to compensate for the quarter-space placement.

7. Low Frequency Filter

The Low Freq Filter switch inserts a low-frequency rolloff into the response curve.

- For applications where a sub-woofer isn't enhancing low-frequency output use the 45Hz (XR624) or 36Hz (XR824) setting or the (Normal) position.
- The Low Freq switch affects the low-frequency content of your mix. Remember how things work in reverse, so removing the deep bass content on playback may actually increase it in the final mix.
- You can use the Low Freq switch's 80Hz position to simulate a smaller loudspeaker, especially one with limited low-frequency capability. You may need to do this if a small speaker is the eventual destination of your mix, or perhaps just to see how your mix sounds on a clock radio.

Removing the low-frequency content also allows you to raise the overall output level somewhat. Low frequency information requires the largest amount of an amplifier's output, so restricting the low-frequency content allows raising the mid-frequency level somewhat. If your client insists on mixing LOUD, this may be a workable strategy.

8. High Frequency Filter

The High Freq Filter switch tailors the overall high-frequency response by ± 2 dB beginning at 10kHz. Leave this switch in the 0 (Normal) position unless:

- You want to subtly brighten or darken the sound of the speakers.
- Perhaps you have hearing loss caused by too many nights in front of a double Marshall stack.
- You just like to mix on the bright side or dull side.

If your mixes consistently sound dull or dark when you listen elsewhere, this usually indicates that your monitors are too bright, relative to your normal hearing. A bit less high-frequency energy usually fixes this, and you can force the mix in this direction by reducing the high-frequency output of the monitors by using the -2 dB position of the switch.

Conversely, if your mixes are consistently too bright, then adding some additional high-frequency energy in the monitors satisfies your ears, and the resultant mix has less HF content.

The timbre of your monitors affects the way that your mixes play on other equipment. Remember that the monitors have a mirroring effect on the mix; if the monitors make something too loud in the mix it usually results in not enough of that thing on tape.

Start with the response modification switches in the factory recommended settings (see Quick Start Section). After prolonged listening, if you notice a trend in your mixes, perhaps making some small adjustments as suggested here will help. It's a real rush to mix really loud. But remember that the resulting mix only sounds good when you play it at least that loud. However strange it may sound, mixes made at lower levels sound even better when played loud; perhaps even a bit bigger than life. Get that sound level meter out. Decide what level you're going to mix at and use the meter to help keep your mixing at that level. Your ears will thank you, and your mixes will be better for it.

9. Power Mode

This 2-position switch turns the amplifiers on or sets them to automatic mode. Use this switch to set the XR series monitors to your preferred mode of operation.

- In the ON position, power amplifiers are live and operate normally. (The rear panel power [2] switch must also be in the ON position.)
- When it's in the Auto On position, the amplifiers turn on and off depending on the presence or absence of an input signal. An input signal level of -45 dBu (minimum) activates the auto-on function. A silent period greater than fifteen minutes activates the auto-off function. The front power LED [11] will reflect the state of the amplifiers.

10. Custom-Tuned Rear Port

XR monitors feature the ELP™ Bass Reflex System which uses the radiation from the rear of the woofer cone to extend the low-frequency response of the speaker. The size, shape and length of the port is carefully designed with respect to the volume of the cabinet and the characteristics of the woofer. This produces increased output capability and extended low-frequency response with zero turbulence.

Front Panel Description

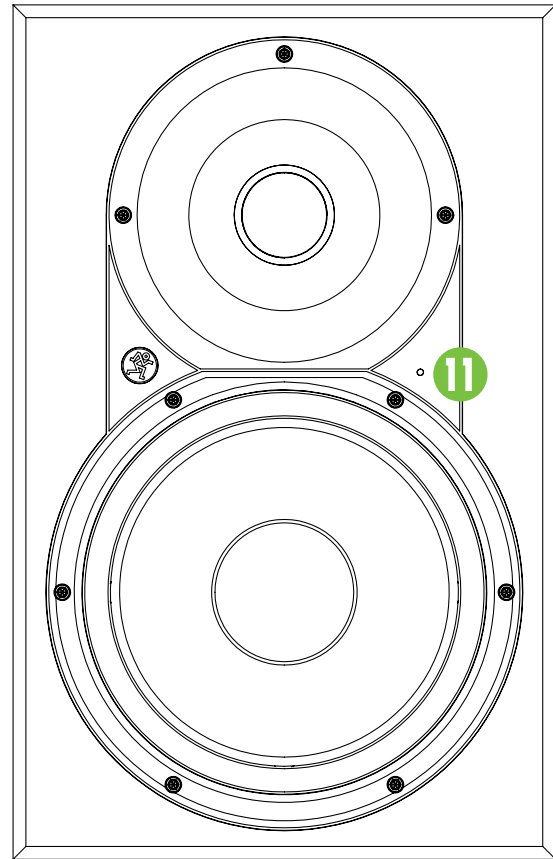

11. Power/Overload Indicator

The front LED indicator illuminates when the power amplifiers are on, and turns off when the amplifiers are in Standby mode or off.

The LED turns red when the overload protection circuit has been triggered.

- Occasional blinking of the overload indicator means that the loudest transients are reaching the maximum drive capability of the amplifiers. This is okay, although distortion may be audible.
- Frequent or continuous blinking of the overload indicator means that you have exceeded the maximum drive allowed for the speakers. The amplifiers are clipping, and the overload protection circuit has taken over, reducing the output level. You should reduce the level from your signal source until the overload indicator blinks occasionally or not at all.

Protection Circuits

There are several mechanisms designed into XR series studio monitors to safeguard the speakers and amplifiers from inadvertent damage.



CAUTION: The protection circuits are designed to prevent damage to the speakers under reasonable and sensible conditions.

Should you choose to ignore the warning signs (i.e., excessive distortion), you can still damage the speakers in XR series studio monitors by overdriving them. Such damage is beyond the scope of the warranty.

Overexcursion Protection

A 12 dB/octave high-pass filter below port tuning just prior to the low-frequency amplifier prevents very low frequencies from being amplified. Excessive low-frequency energy below the usable frequency range can damage the woofer by causing it to “bottom out,” also known as overexcursion, which is equivalent to a mechanical form of clipping.

Thermal Protection

All amplifiers produce heat. XR series studio monitors are designed to be efficient both electrically and thermally.

- If for some reason the heatsink gets too hot, a thermal switch activates and turns off the amplifier.
- When the heatsink cools down to a safe temperature, the thermal switch resets and normal operation resumes.
- If the heatsink temperature again gets too hot, the shutdown process repeats. Should this happen, make sure that airflow to the rear of the cabinet is not restricted.

Overload Protection

- If you see the overload indicator [11] blinking more than just occasionally, it's an indication that you should reduce the signal level coming from your mixer or other signal source.
- The blinking overload indicator means the driver thermal overload protection has activated a compressor. This reduces the input level to the amplifiers.
- The compressor was designed to protect the speakers and its action is highly audible.

Input Signal Wiring

We recommend using high-quality, shielded cables to connect the signal source to the signal input jack [4] on all XR series studio monitors. Two types of input connectors are provided to interface with virtually any application you may have:

- Balanced microphone cables work well with the XLR input.
- Balanced TRS cables work well with the 1/4" input.

NOTE: Route the cable away from AC power cords and outlets. These are common sources for hum in an audio signal. Wall warts and line lumps are especially insidious hum inducers!

CAUTION: Do not attempt to connect a speaker output directly to the input of a XR series studio monitor! Speaker levels are much higher than line levels and can damage the input circuitry in the XR series studio monitors.

Care and Cleaning

XR Series Studio Monitors will provide many years of reliable service if you follow these guidelines.

- Avoid exposing the monitors to moisture.
- Avoid exposure to extreme cold (below freezing temperatures).
- Use a dry cloth to clean the cabinets. Only do this when the power is turned off.

Appendix A: Service Information

Details concerning Warranty Service are spelled out in the Warranty section on page 15.

If you think your monitor has a problem, please check out the following troubleshooting tips and do your best to confirm the problem. Visit the Support section of our website (www.mackie.com/support) where you will find lots of useful information such as FAQs and documentation. You may find the answer to the problem without having to send your monitor away.

Troubleshooting

No Power

- Our favorite question: Is it plugged in?
- Make sure the power cord is securely seated in the IEC socket (1) and plugged all the way into the AC outlet.
- Make sure the AC outlet is live (check with a tester or lamp).
- Is the power [2] switch pushed in and the Power Mode [9] switch on the rear panel in the ON position
- Is the power LED [11] on the front panel illuminated? If not, make sure the AC outlet is live. If so, refer to “No Sound” below.
- If the power LED is not illuminated, and you are certain that the AC outlet is live, it will be necessary to have the XR monitor serviced. There are no user-serviceable parts inside. Refer to “Repair” at the end of this section to find out how to proceed.

No Sound

- Is the power LED [11] on the front panel illuminated? If not, refer to “No Power” above.
- Is the Input Sensitivity [5] control turned up?
- Is the signal source turned up? Make sure the signal level from the mixing console (or whatever device immediately precedes the studio monitor) is high enough to produce sound.
- If it's a stereo pair, try switching them around. For example, if a left output is presumed dead, switch the left and right cords at the monitor end. If the problem switches sides, it's not the monitor. It could be a bad cable, or no signal from the mixer.

Bad Sound

- Is the input connector plugged completely into the jack? If using a 1/4" TS or TRS plug, make sure it is plugged all the way in.
- Is it loud and distorted? Reduce the signal level at the mixer.
- If possible, listen to the signal source with headphones plugged into the preamp stage. If it sounds bad there, it's not the monitor.
- Too much bass or not enough bass? Move around the room and see if the bass response changes. It's possible your listening position coincides with a room mode where the low frequencies either become exaggerated or nulled. If so, try moving the monitors to a different position, or moving your listening position.

Noise/Hum/Buzz

- Check the signal cable between the mixer and the monitor. Make sure all connections are secure. These problems usually produce crackling noises, hum, or buzz.
- If connecting an unbalanced output to a XR monitor balanced input, make sure the shield is connected to the unbalanced ground of the source and to pins 1 and 3 of the XLR (or the sleeve and ring of the TRS jack).
- If a CATV cable is connected to the system, try disconnecting it. If the hum goes away, call your cable carrier to check for proper grounding of the cable.
- Make sure the signal cable is not routed near AC cables, power transformers, or other EMI sources (including wall warts and line lumps!). These sources usually produce hum.
- Is there a light dimmer or other triac-based device on the same AC circuit as the monitor? Dimmers cause buzzing noises. Use an AC line filter or plug the monitor into a different AC circuit.
- Excessive hiss is an indication of an incorrect gain setting somewhere before the speaker.
- If possible, listen to the signal source with headphones plugged in. If it sounds noisy there, it's not the monitor.

Repair

For warranty service, please refer to the warranty information on page 15.

Non-warranty service is available at a factory-authorized service center. To locate the nearest service center, visit www.mackie.com, click “Contact Tech Support” and select “Locate a Service Center or Distributor” [3]. Service for XR Series monitors living outside the United States may be obtained through local dealers or distributors.

If you do not have access to our website, please call our Tech Support department at 1-800-898-3211 (normal business hours, Pacific Time), to explain the problem. They will tell you where the nearest factory-authorized service center is located in your area.

Need help with the XR Series Studio Monitor?

- Visit www.mackie.com and click Support to find: FAQs, manuals, and addendums.
- Telephone 1-800-898-3211 to speak with one of our splendid technical support chaps (Monday through Friday, normal business hours, Pacific Time).

Appendix B: Technical Information

XR Series Specifications

Acoustic Performance

Frequency Response (-3 dB):	45 Hz – 22 kHz [XR624] 36 Hz – 22 kHz [XR824]
Sound Pressure Level @ 1 meter, +4 dBu into Balanced Input:	107 dB SPL @ 1m [XR624] 109 dB SPL @ 1m [XR824]
Maximum SPL Per Pair:	113 dB SPL @ 1m [XR624] 115 dB SPL @ 1m [XR824]

Transducers

Low Frequency:	6.5 in / 165 mm Kevlar® woofer [XR624] 8.0 in / 203 mm Kevlar® woofer [XR824]
High Frequency:	1 in / 25 mm black anodized aluminum tweeter

Amplifiers

Low Frequency Power:	100 Watts
High Frequency Power:	60 Watts
Type:	Class D power amplifier

Electronic Crossover

Crossover Type:	Linkwitz-Riley, 24 dB/octave
Crossover Frequency:	2.7 kHz [XR624] 2.2 kHz [XR824]

Equalization

Low Frequency EQ:	-3 dB @ 45 Hz [XR624] -3 dB @ 36 Hz [XR824] -3 dB @ 80 Hz
High Frequency EQ:	±2 dB @ 10 kHz, shelving
Acoustic Space Filter:	Whole: Flat Half: -2 dB @ 100 Hz Quarter: -4 dB @ 100 Hz

Input Types

Input Impedance:	20 kΩ balanced bridging 10 kΩ unbalanced
Input Type:	Balanced Differential (XLR and 1/4" TRS)
Input Protection:	RFI and Level Protected
Maximum Input Level:	+20 dBu

AC Power Requirements

AC Connector:	3-pin IEC 250 VAC, 16 A male 100 – 120 VAC, 50 – 60 Hz, 150W 220 – 240 VAC, 50 – 60 Hz, 150W
Fuse:	115 VAC: T 2.5 AL / 250 V 230 VAC: T 1.25 AL / 250 V
Auto On/Off Standby Mode	<0.5 Watts

Physical Dimensions and Weight

Enclosure:	All-wood MDF construction and internal cabinet bracing
Damping:	Open cell adiabatic "foam fill" acoustic batting
Finish:	Black wood grain vinyl and black paint

XR624:

Dimensions:	
Height:	13.1 in / 333 mm
Width:	8.6 in / 218 mm
Depth:	12.6 in / 320 mm
Weight:	23.4 lb / 10.6 kg

XR824:

Dimensions:	
Height:	16.8 in / 427 mm
Width:	10.8 in / 274 mm
Depth:	13.8 in / 351 mm
Weight:	34.6 lb / 15.7 kg

Disclaimer

LOUD Technologies is always striving to improve our products by incorporating new and improved materials, components and manufacturing methods. Therefore, we reserve the right to change these specifications at any time without notice.

XR624 Dimensions

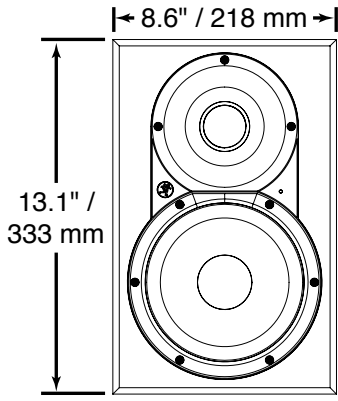

XR824 Dimensions

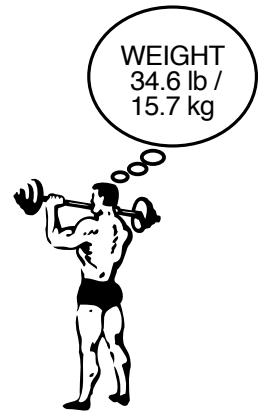
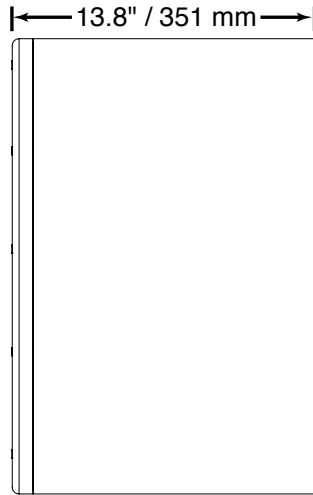
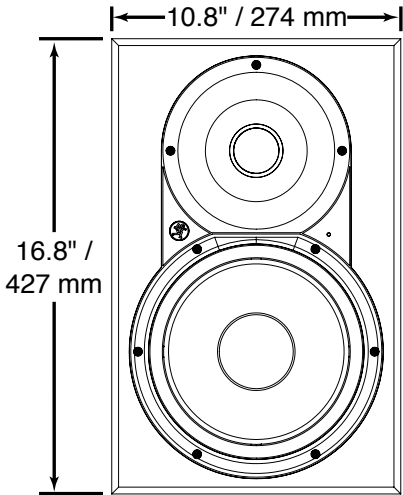

Please keep your sales receipt in a safe place.

This Limited Product Warranty ("Product Warranty") is provided by LOUD Technologies Inc. ("LOUD") and is applicable to products purchased in the United States or Canada through a LOUD-authorized reseller or dealer. The Product Warranty will not extend to anyone other than the original purchaser of the product (hereinafter, "Customer," "you" or "your").

For products purchased outside the U.S. or Canada, please visit www.mackie.com to find contact information for your local distributor, and information on any warranty coverage provided by the distributor in your local market.

LOUD warrants to Customer that the product will be free from defects in materials and workmanship under normal use during the Warranty Period. If the product fails to conform to the warranty then LOUD or its authorized service representative will at its option, either repair or replace any such nonconforming product, provided that Customer gives notice of the noncompliance within the Warranty Period to the Company at: www.mackie.com or by calling LOUD technical support at 1.800.898.3211 (toll-free in the U.S. and Canada) during normal business hours Pacific Time, excluding weekends or LOUD holidays. Please retain the original dated sales receipt as evidence of the date of purchase. You will need it to obtain any warranty service.

For full terms and conditions, as well as the specific duration of the Warranty for this product, please visit www.mackie.com.

The Product Warranty, together with your invoice or receipt, and the terms and conditions located at www.mackie.com constitutes the entire agreement, and supersedes any and all prior agreements between LOUD and Customer related to the subject matter hereof. No amendment, modification or waiver of any of the provisions of this Product Warranty will be valid unless set forth in a written instrument signed by the party to be bound thereby.



Correct disposal of this product: This symbol indicates that this product should not be disposed of with your household waste, according to the WEEE directive (2012/19/EU) and your national law. This product should be handed over to an authorized collection site for recycling waste electrical and electronic equipment (EEE). Improper handling of this type of waste could have a possible negative impact on the environment and human health due to potentially hazardous substances that are generally associated with EEE. At the same time, your cooperation in the correct disposal of this product will contribute to the effective usage of natural resources. For more information about where you can drop off your waste equipment for recycling, please contact your local city office, waste authority, or your household waste disposal service.



**16220 Wood-Red Road NE
Woodinville, WA 98072 • USA
Phone: 425.487.4333
Toll-free: 800.898.3211
Fax: 425.487.4337
www.mackie.com**
